



Thorium: an energy source for the world of tomorrow

JOINT EPS-SIF INTERNATIONAL SCHOOL ON ENERGY
Villa Monastero, Varenna, Italy
July 23, 2014

Jean-Pierre Revol
Centro Fermi, Roma
iTheC, Geneva



Primary energy world consumption

Million tonnes oil equivalent

Today the world behaves as a 15 TW engine ($\approx 2\text{kW}/\text{capita}$) +2% between 2012 and 2013

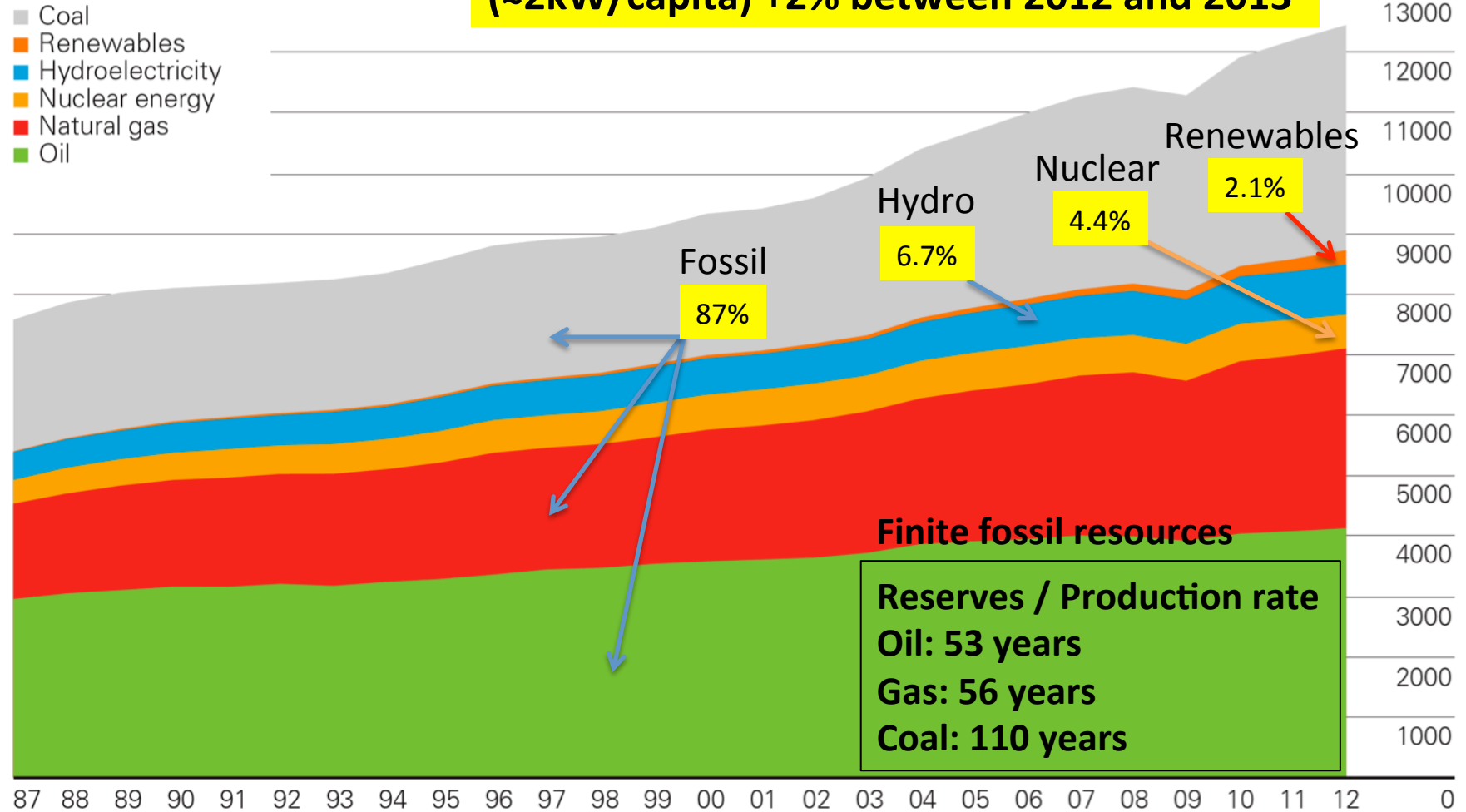

BP Statistical Review of World Energy 2012
© BP 2012

If, by end of 21st century, people in developing countries are allowed to live as well as we do in Europe today, then, the world power consumption will have to increase by a factor 3 or more.

Burning fossil fuel till the end?

- ❑ **Global warming?** Atmospheric CO₂ level higher than ever in the past 15 million years, increasing faster than ever before (IPCC report, March 2014 > 2°C more likely than ≤ 2°C)
- ❑ **Air pollution?**
 - 👉 Burning coal cost Europe alone 42.8 billion Euros in annual health care expenses (2013 report by the Health and Environment Alliance)
 - 👉 The ambient air pollution caused the premature deaths of > 400 000 Chinese in 2013
 - 👉 WHO: in 2012 around 7 million people died – 1 in 8 of total global deaths – as a result of air pollution exposure

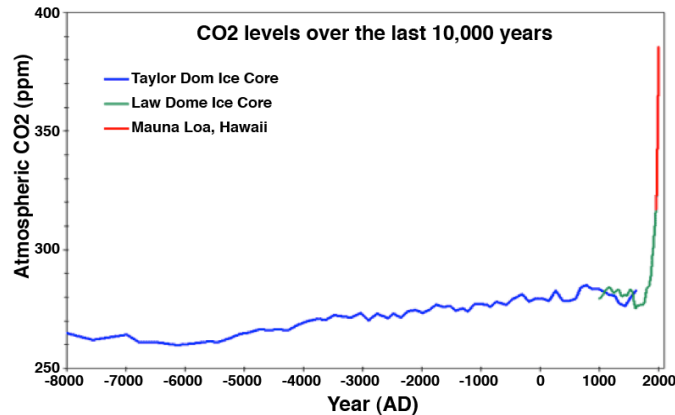

- ❑ **Running out?** The current tendency is to increase the use of fossil fuel
- ❑ **Way out? innovate!**

Energy R&D

- ❑ Innovation implies investment in both **fundamental research** and **applied research**
 - ☞ Brings the possibility of (good) surprises
- ❑ Relying entirely on wind and solar energy by the end of the century would imply increasing their contribution to the world energy by a factor 130 or more (quite a challenge, and most likely not realistic)
- ❑ Energy R&D has to **be systematic**, without prejudice:
 - ☞ Improve energy efficiency, storage, transport, etc.
 - ☞ Develop renewable energies
 - Wind, Solar Photovoltaic, Solar thermal, Biomass (E.-D. Schulze)?, Geothermal, Ocean tides, waves, etc.
 - ☞ R&D on nuclear fusion (no conceptual solution yet)
(Magnetic confinement: ITER, Inertial confinement: NIF, Mégajoule)
 - ☞ **Improve nuclear fission energy** (it works already!)
 - Generation IV (critical fast reactors on nuclear industry agenda)
 - Innovative nuclear systems based on **thorium**

Thorium Energy Conference (ThEC13)

- ❑ Organized by the **international Thorium Energy Committee** (iThEC, <http://www.ithec.org>)
- ❑ Participants from 32 countries, 47 speakers, including some prestigious personalities



- ❑ Representatives of both **India and China cited energy issues as their prime concern** and announced strong motivations to do R&D on thorium
<http://indico.cern.ch/event/thec13>



Xu Hongjie

China's Energy Challenge



Analysis and forecast on national electric power in China: In 2030, the electricity demand of per person will be about 2KW, total generation capacity will reach about 3000GW, the MW - level power stations will need 3000.

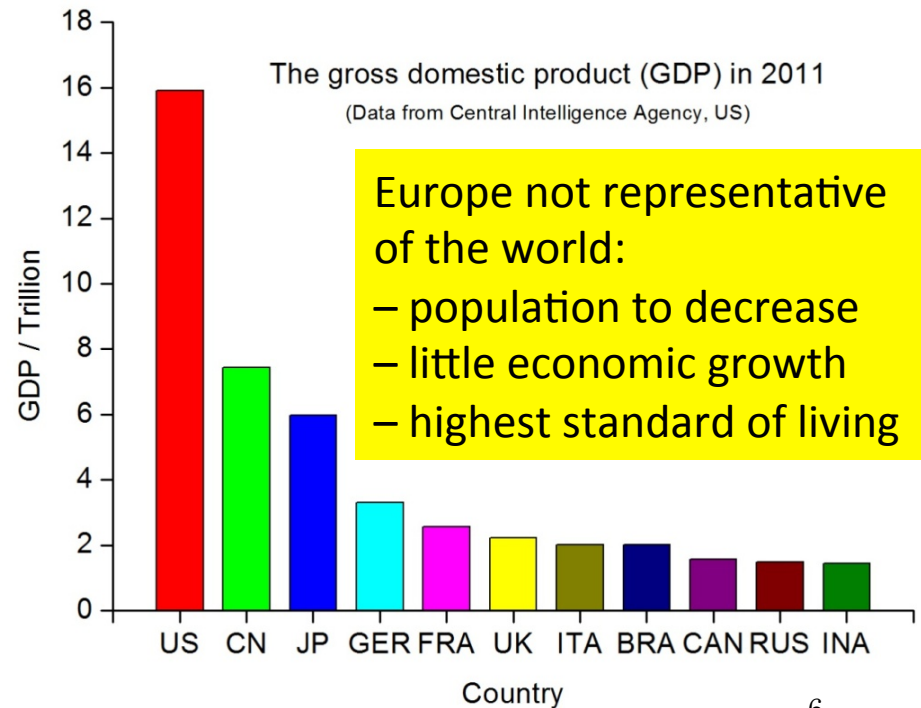
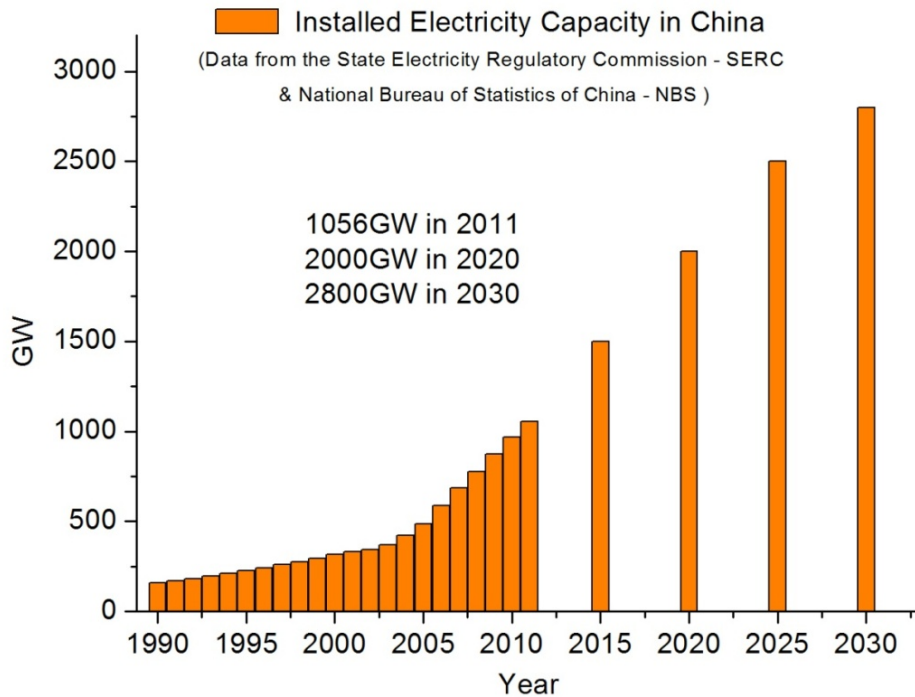

The interest of nuclear industry

- ❑ The increasing worldwide interest in thorium is finally reaching nuclear industry. For the first time, thorium officially mentioned by a French main nuclear actor.
- ❑ At ThEC13, AREVA and SOLVAY announced an agreement on thorium:

AREVA and SOLVAY join their know-how to add value to thorium's entire life cycle

Luc van den Durpel
CERN, Oct. 29, 2013

- ❑ However, AREVA is only considering an “adiabatic” transition from uranium to thorium (80-100 years), starting by inserting a few thorium fuel elements in a uranium reactor.

Thorium in Light Water Reactors

Thor Energy (The Norwegian Thorium Initiative) collaborates with Westinghouse to carry out **thorium fuel tests** in the Halden research reactor.

- 2 Rods 85%Th - 15%Pu pellets, ITU, Germany
- 2 Rods 7%Th – 93%UOX, IFE, Norway
- 1 Rod 65%Th – 35%UOX, IFE, Norway
- 1 UOX Reference rod

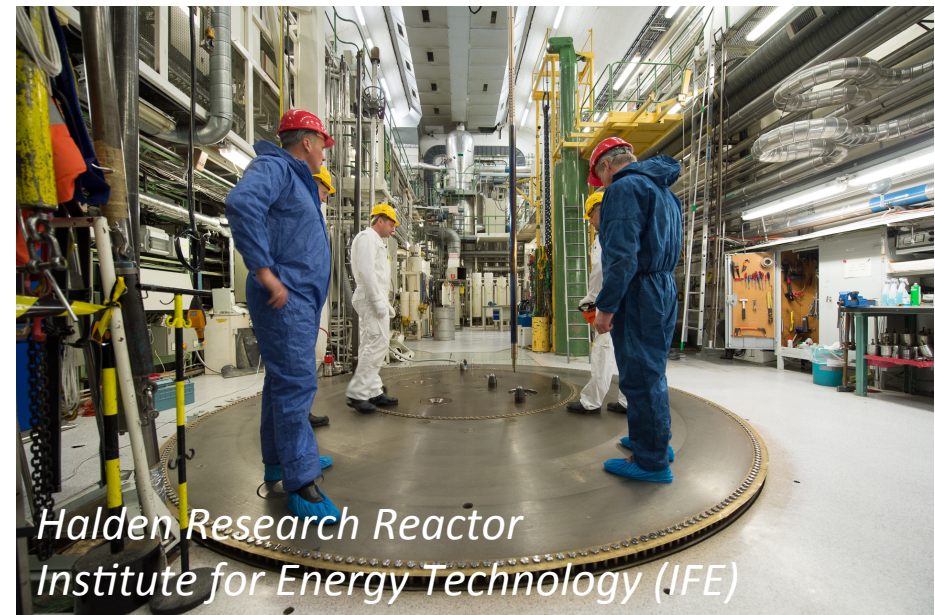
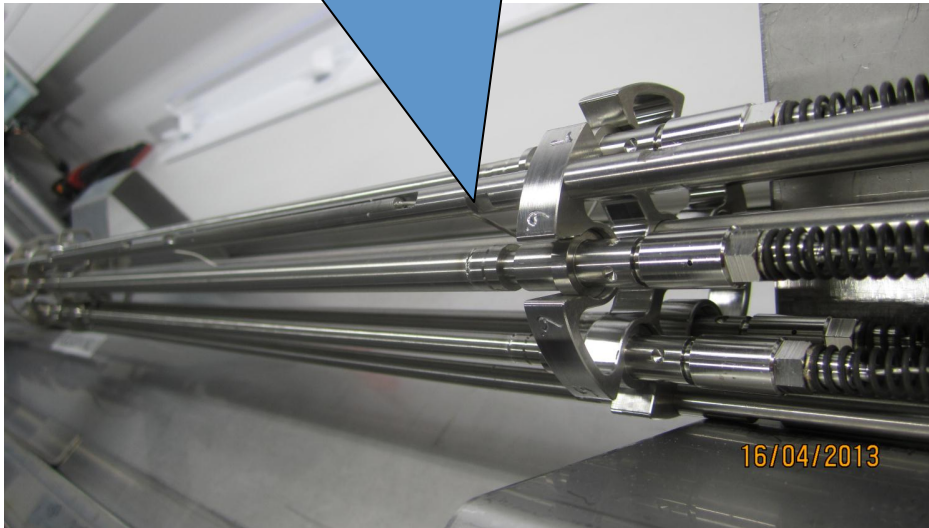

Nuclear fission energy

❑ Why is it a priori attractive?:

- No CO₂, no air pollution (NO_x, etc.), concentrated
- Has the potential to produce abundant (base load) electric energy
- Nuclear fission technology exists and is well understood
- Breeding can make it essentially “sustainable” on the human time scale

❑ Shortcomings of the **PRESENT** generation of thermal neutron systems based on uranium:

- Accidents (Chernobyl, Three Mile Island, Fukushima)
- Waste management (storage over \leq one million years is the only option developed so far)
- Proliferation of nuclear weapons (uranium \approx military)
- Sustainability (<100yr at present rate)

❑ Can one make nuclear energy acceptable to Society?

Can a different nuclear energy based on **thorium** instead of uranium have the potential for eliminating all of the above issues of the present nuclear power scheme?

Thorium ($^{232}\text{Th}_{90}$)

- ❑ **Abundant** (1.2×10^{14} tons in the Earth's crust), as much as lead, and three to four times more than uranium
- ❑ Recovering only one part per million (10^{-6}), that is 1.2×10^8 tons, would provide the present world power consumption of 15 TW, for 18'000 years. "Thorium is a source of energy essentially sustainable on the human time scale" C. Rubbia @ ThEC13
- ❑ **Isotopically pure**, α -decay with a half-life of 14 billion years (almost stable)
- ❑ Thorium occurs in several minerals including thorite (ThSiO_4), thorianite ($\text{ThO}_2 + \text{UO}_2$) and monazite (**Ce, La, Nd, Th**) PO_4). **Often a by-product of mining for rare earths** (lanthanides + scandium and yttrium), tin, coal and uranium tailings
- ❑ Known and estimated resources: $\approx 7 \times 10^6$ tons (IAEA); poor indicator because not searched for systematically; ≈ 1000 years at present world energy consumption



Monazite sample containing 2 to 3% of thorium mixed with rare earths (from the Steenkampskraal mine, South Africa – Trevor Blench)

Fission energy from $^{232}\text{Th}_{90}$

- ❑ Thorium is **fertile**, not fissile, so it can **ONLY be used** in breeding mode, by producing ^{233}U which is fissile
- ❑ However, this gives a potential factor 140 gain compared to ^{235}U in PWR (in addition to the factor 3 to 4 in abundance)

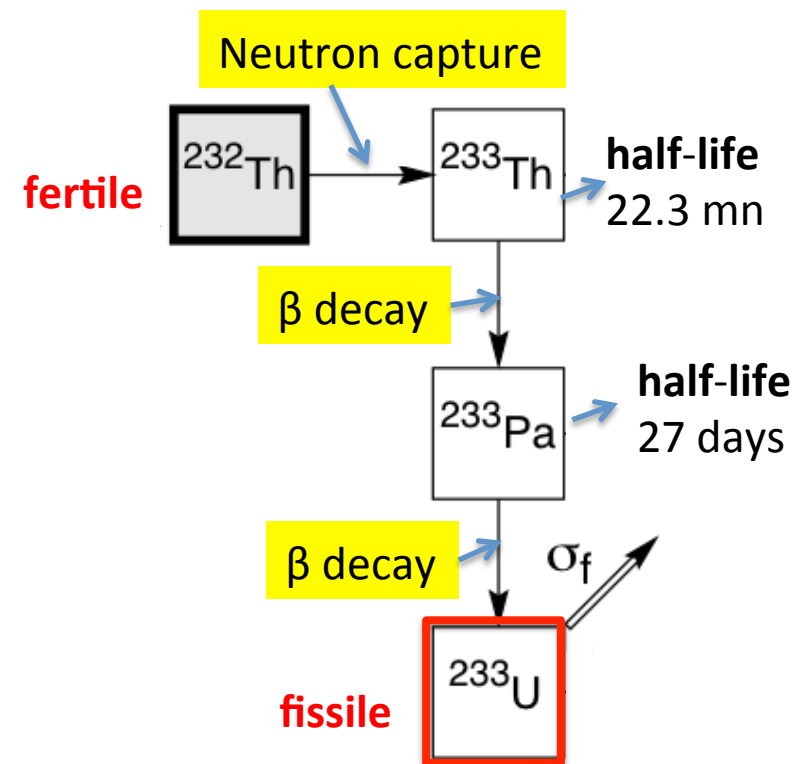

Fission energy from $^{232}\text{Th}_{90}$

- ❑ Thorium is **fertile**, not fissile, so it can **ONLY be used** in breeding mode, by producing ^{233}U which is fissile
- ❑ However, this gives a potential factor 140 gain compared to ^{235}U in PWR (in addition to the factor 3 to 4 in abundance)

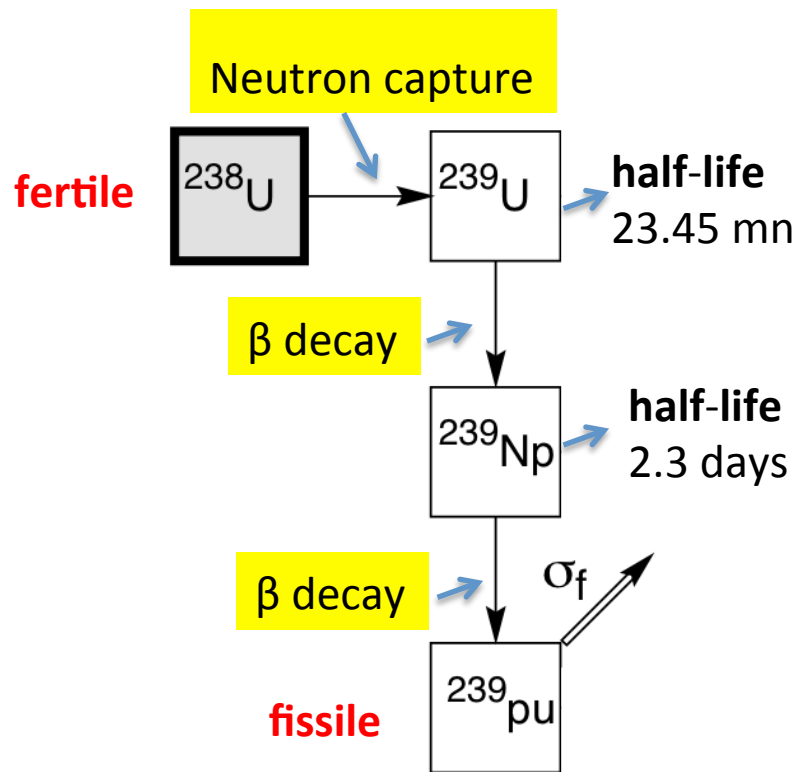

Uranium chain

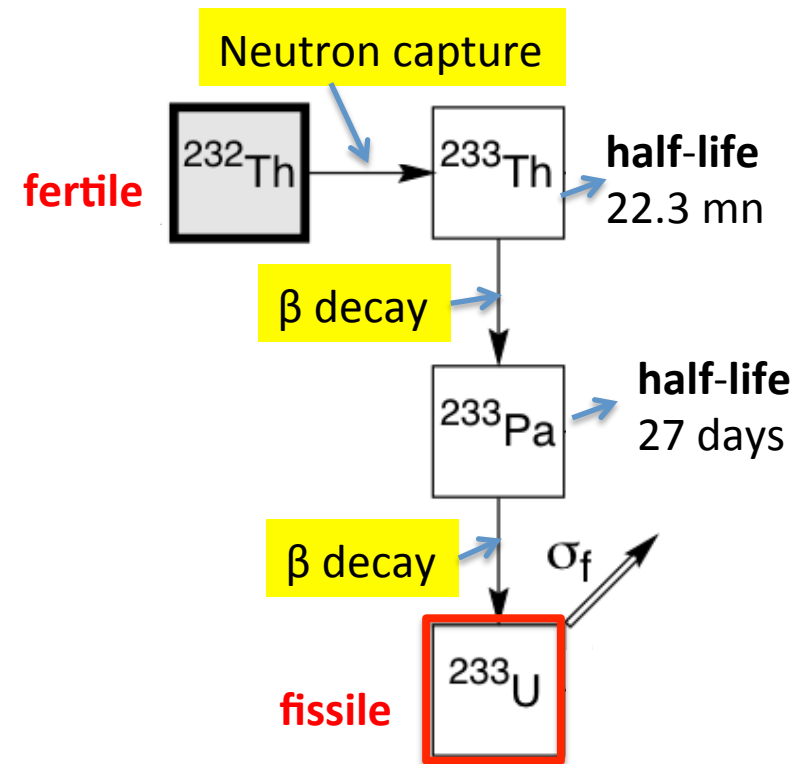

Thorium chain

Fission energy from $^{232}\text{Th}_{90}$

- ❑ Thorium is **fertile**, not fissile, so it can **ONLY be used** in breeding mode, by producing ^{233}U which is fissile
- ❑ However, this gives a potential factor 140 gain compared to ^{235}U in PWR (in addition to the factor 3 to 4 in abundance)
- ❑ Thorium dioxide (ThO_2) has the highest melting point (3300 °C compared to 2865 °C for UO_2) of all oxides and is one of the best refractory materials
- ❑ Minimizes nuclear waste production, **can be used to destroy existing nuclear waste**

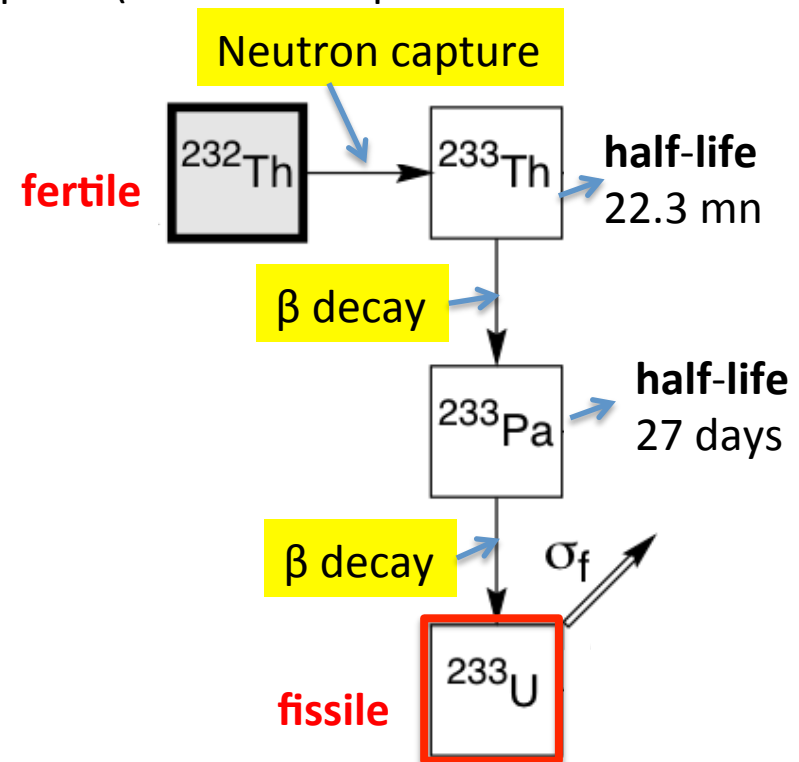

Nuclear Waste

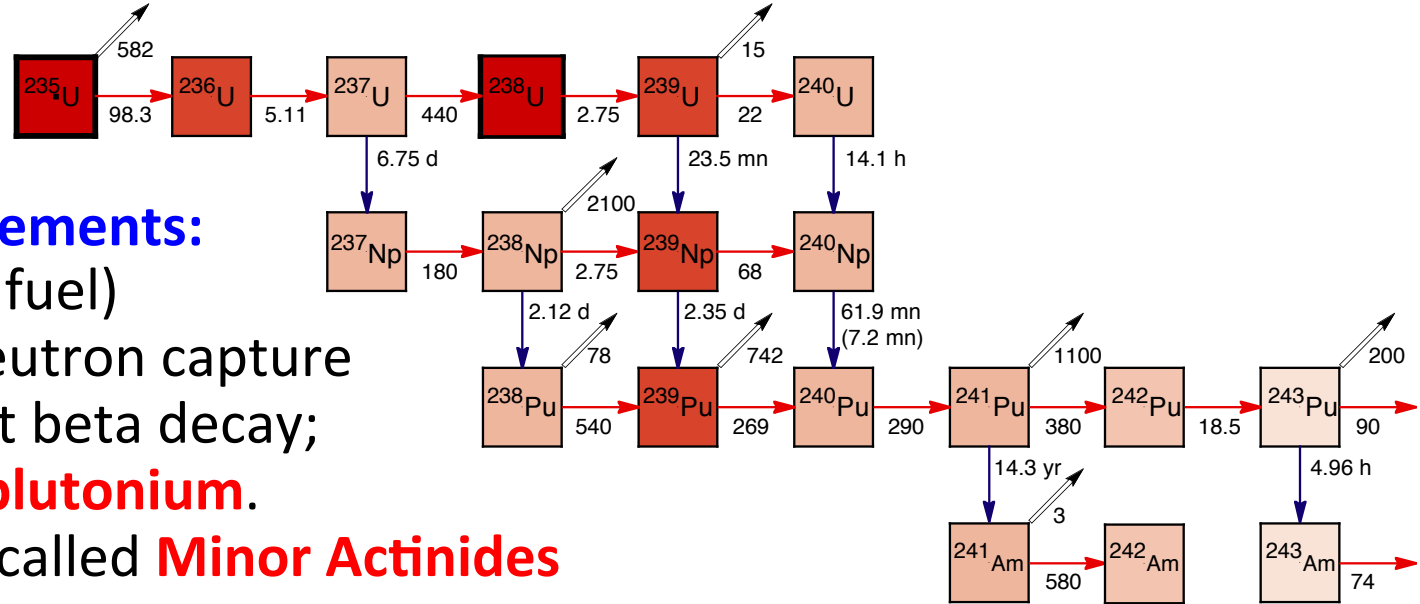

- ❑ **TRansUranic elements:**
 (1.1% of spent fuel)
 produced by neutron capture
 and subsequent beta decay;
 dominated by **plutonium**.
 The others are called **Minor Actinides**

- ❑ **Fission Fragments:**
 (4% of spent fuel)
 the results of fissions

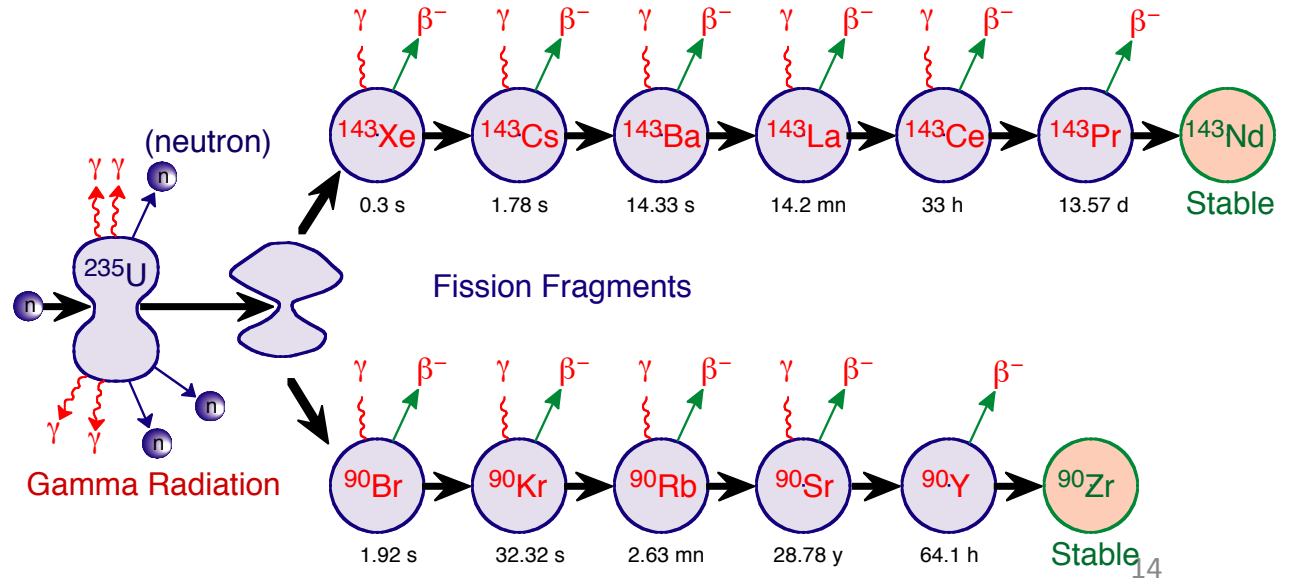

Nuclear Waste

- TRU constitute by far the main problem [long lifetime – reactivity].

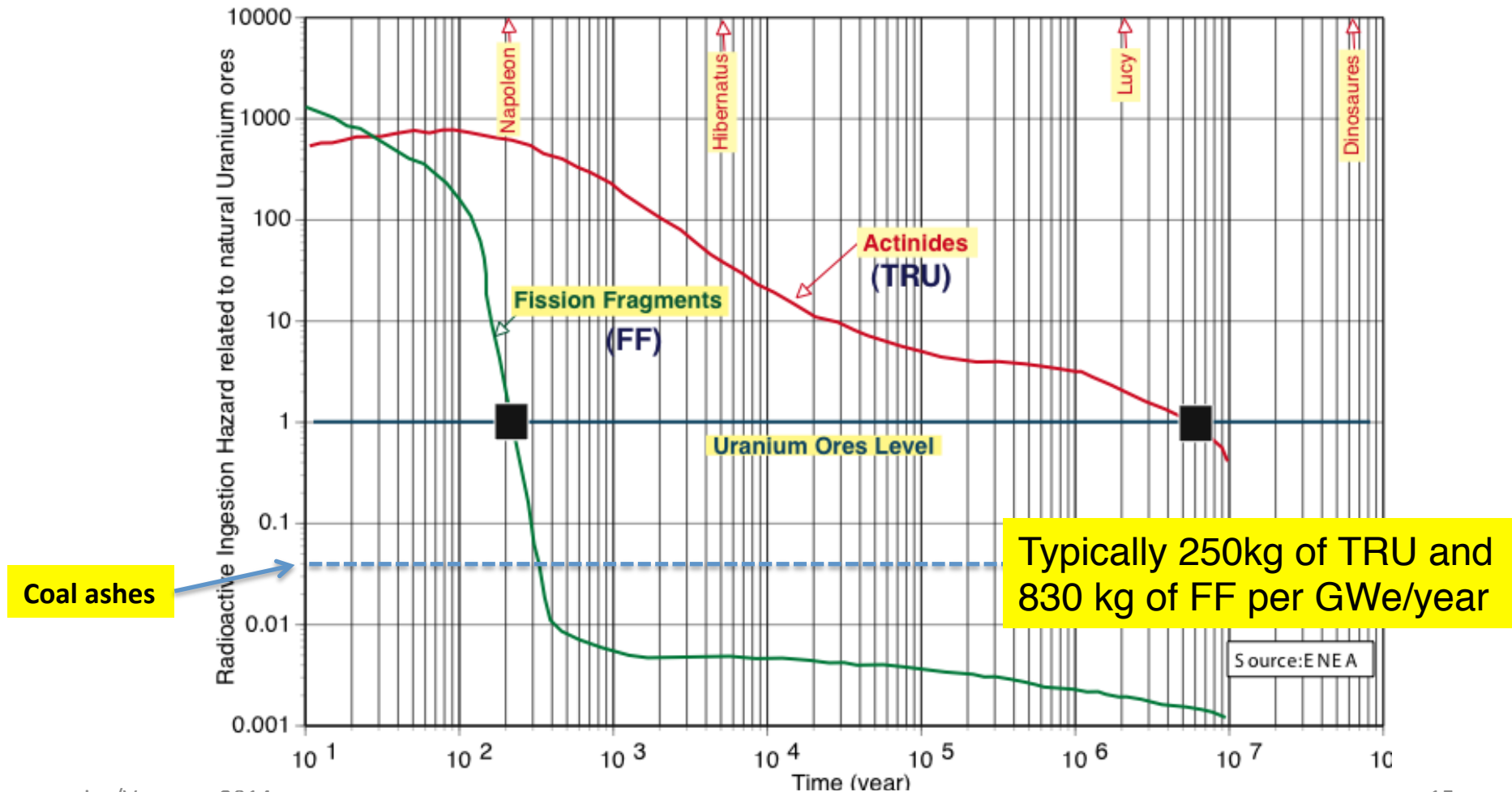

Thorium and nuclear waste

- ❑ Thorium minimizes nuclear waste production, because it is **7 neutron captures away from plutonium-239**

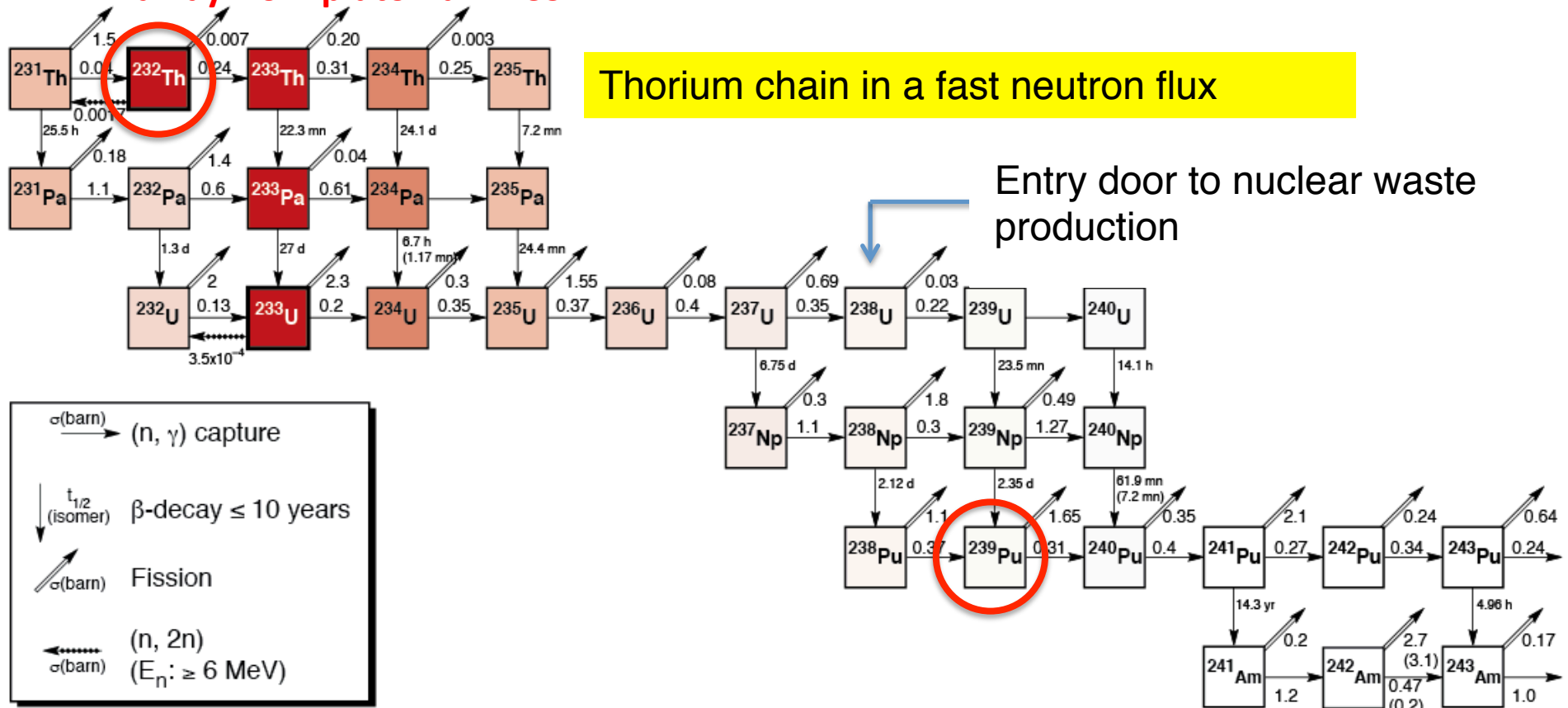

- ❑ Used in a **fast neutron flux**, thorium represents a unique potential for nuclear waste elimination

Why fast neutrons?

Advantages of fast neutrons:

- Favourable to breeding
- Enhances TRU fission probability
- No need to separate out Pu!
simplifies reprocessing
(Pyro-Electro)
- Reduces captures on FF, **extends burnup (better use of fuel)**
(120 GW.day/t achieved in fast electro-breeder at Argonne N.L., and in EA simulation)

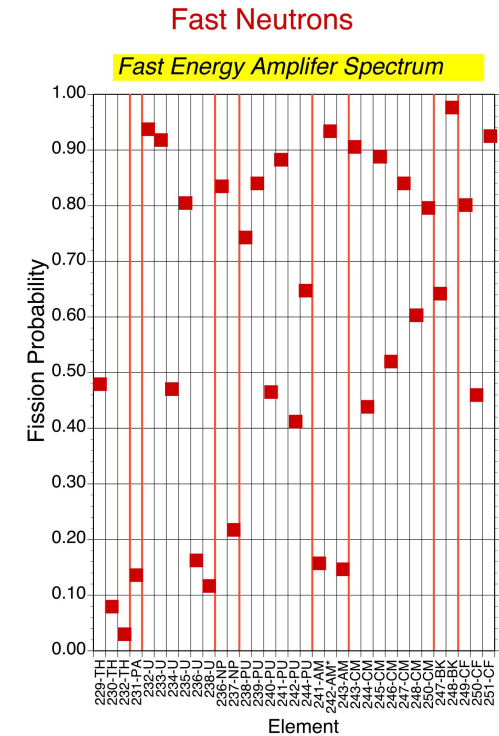
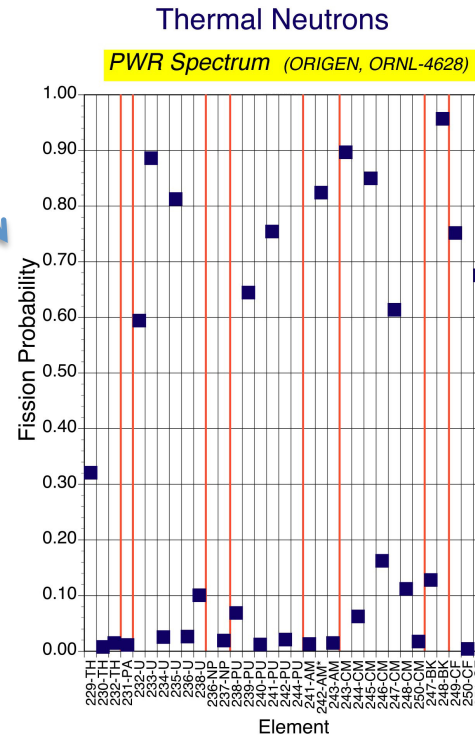
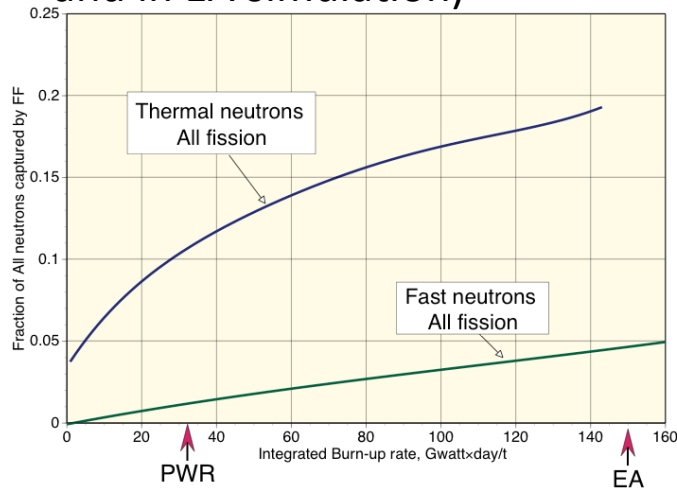

Fast spectrum, implies as little moderation as possible:

- Sodium or gas used in GENERATION IV
- Molten salts in MSR
- Pb or Pb-Bi eutectic in ADS systems

Fission energy from $^{232}\text{Th}_{90}$

- ^{233}U is an excellent fuel for a breeder system

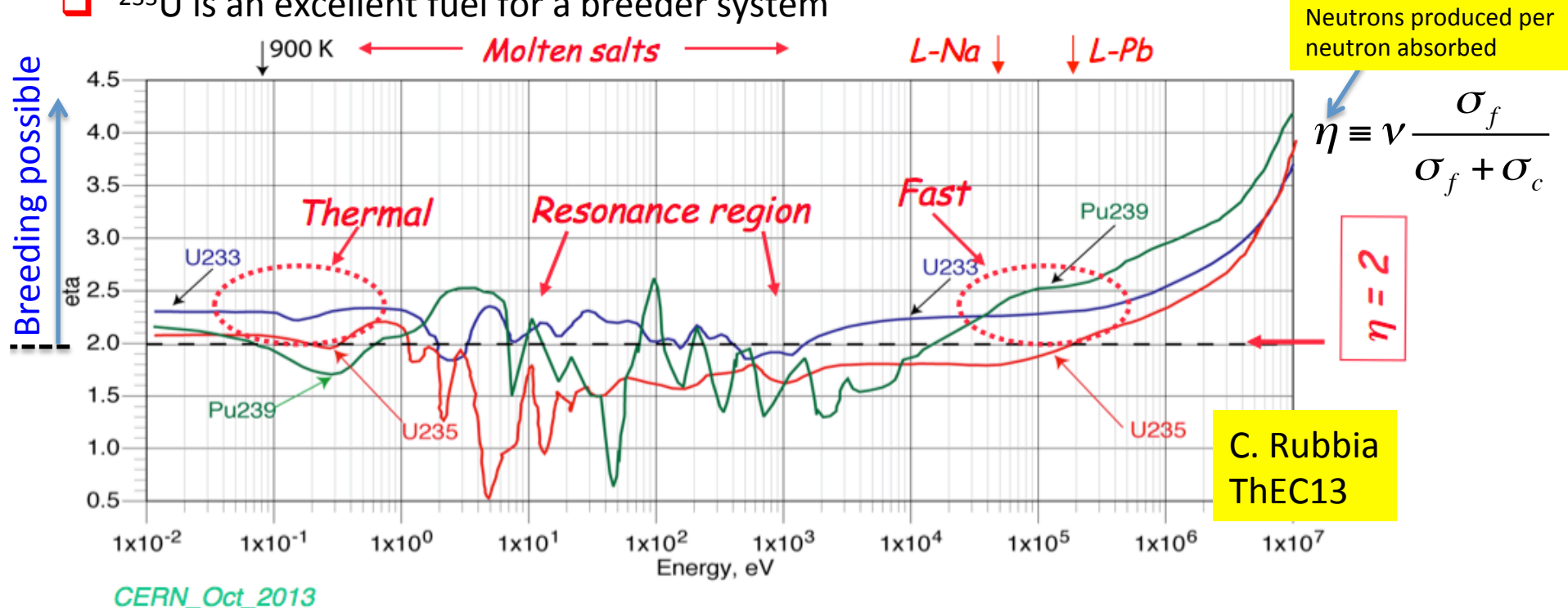

- But the other elements in the fuel have to be taken into account (^{232}Th , ^{238}U). Thorium + ^{233}U cannot be substituted simply to PWR fuel because of neutron inventory issues (capture rate on thorium and long half-life of ^{233}Pa)

Neutron Captures

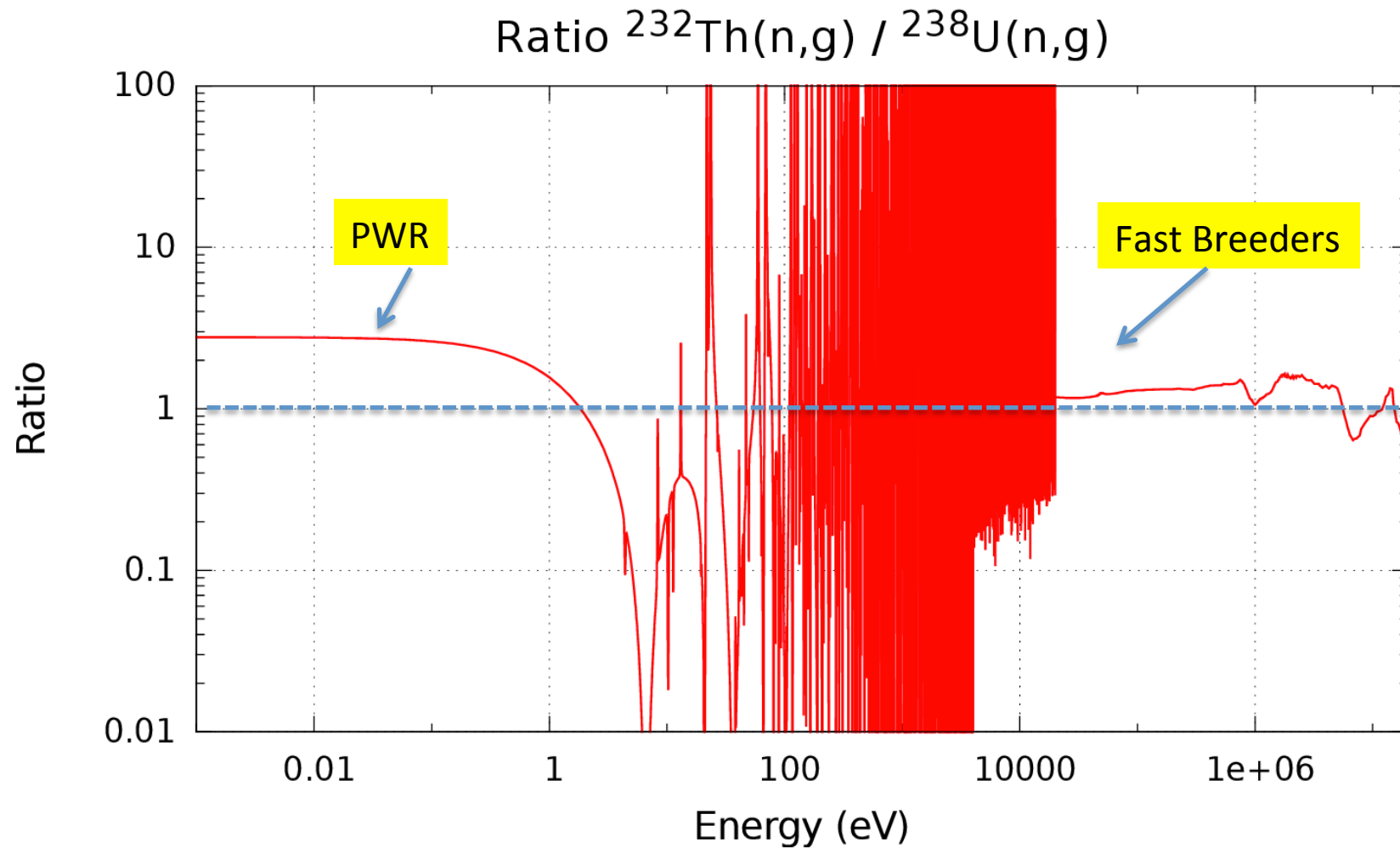

How to use thorium in practice?

□ Three general options?

☞ **Thorium blankets** around reactors, to breed ^{233}U and introduce ^{233}U in fuel



☞ **Continuously move the fuel out**, such as to always have fresh fuel

- Pebble bed reactors (once through)
- Molten salt reactors (reprocessing on-line)

☞ **Accelerator Driven Systems (ADS)**, providing an external neutron source: this is the solution proposed by C. Rubbia at CERN in the 1990's

Thorium blanket: Indian strategy

- ❑ India, with little uranium resources but a lot of thorium, has the most advanced practical scheme for using thorium (including front-end and back-end of the fuel cycle):
 - ☞ Use **heavy water reactors** (CANDU) or **LWR** to produce **plutonium**
 - ☞ Use **sodium cooled U-Pu fast reactors** with a thorium blanket to breed ^{233}U
 - ☞ Reprocess blankets and manufacture ^{233}U -Th fuel for **advanced fast reactors or heavy water reactors**

- ❑ The Indian scheme works. However, several issues remain concerning the **complexity** (three technologies), the **sustainability** and **nuclear waste management**.

Pebble bed critical reactors

❑ Proposed by Farrington Daniels at Oakridge, in the 1940s. Initial developments in Germany (AVR Jülich), followed by THTR-300MW (1983-1989). New developments in South Africa, now in the United States and Turkey.

- ☞ Presented as passively safe, because high temperature systems can be cooled by natural air convection
- ☞ Not discussed at ThEC13

❑ Several severe issues to be resolved:

- ☞ No containment building if cooling by natural air convection
- ☞ Uses flammable graphite as moderator
- ☞ Produces more high-level nuclear waste than current nuclear reactor designs
- ☞ Relies heavily on pebble integrity and fuel handling (pebble accident in THTR-300)
- ☞ Water ingress is a danger
- ☞ Reprocessing of spent fuel virtually impossible

Pebble Bed Reactor scheme

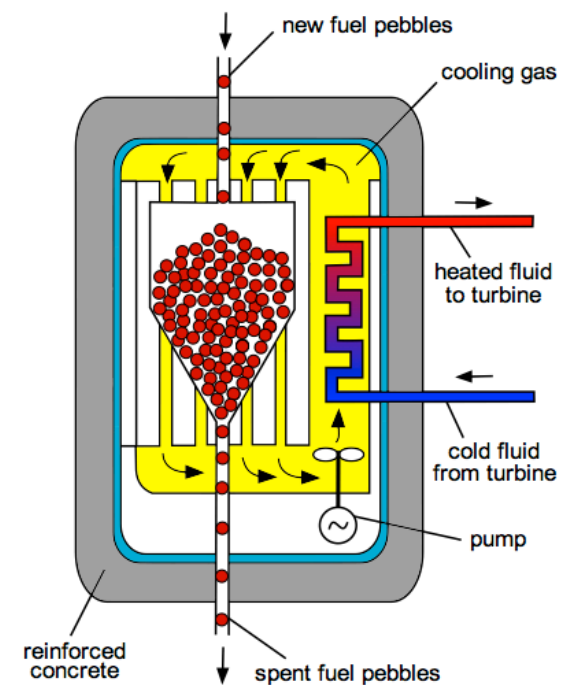

Molten salt critical reactors

- ❑ This is clearly a technology that is concentrating industry's interest (10 talks related to the subject at ThEC13): China, India, UK, USA, Czech Republic, France, Switzerland
- ❑ Pioneered at Oakridge in 1960 (Molten Salt Reactor Experiment, UF₄, 7.4MWth)
- ❑ Advantages:
 - Liquid fuel allows extending burnup indefinitely, because of reprocessing on-line
 - High temperature (500°C – 600°C), heat produced directly in heat transfer fluid
 - Passive cooling for decay heat removal
- ❑ **Several severe issues:** neutron emission outside core, on-line chemistry failure, corrosion, licencing issues, etc.
- ❑ Presently not using a fast neutron spectrum (R&D should be extended to other salts – PbCl₃, to minimize waste)
- ❑ There is a particularly well focussed and most ambitious effort in China (Xu Hongjie, Shanghai Institute of Applied Physics)

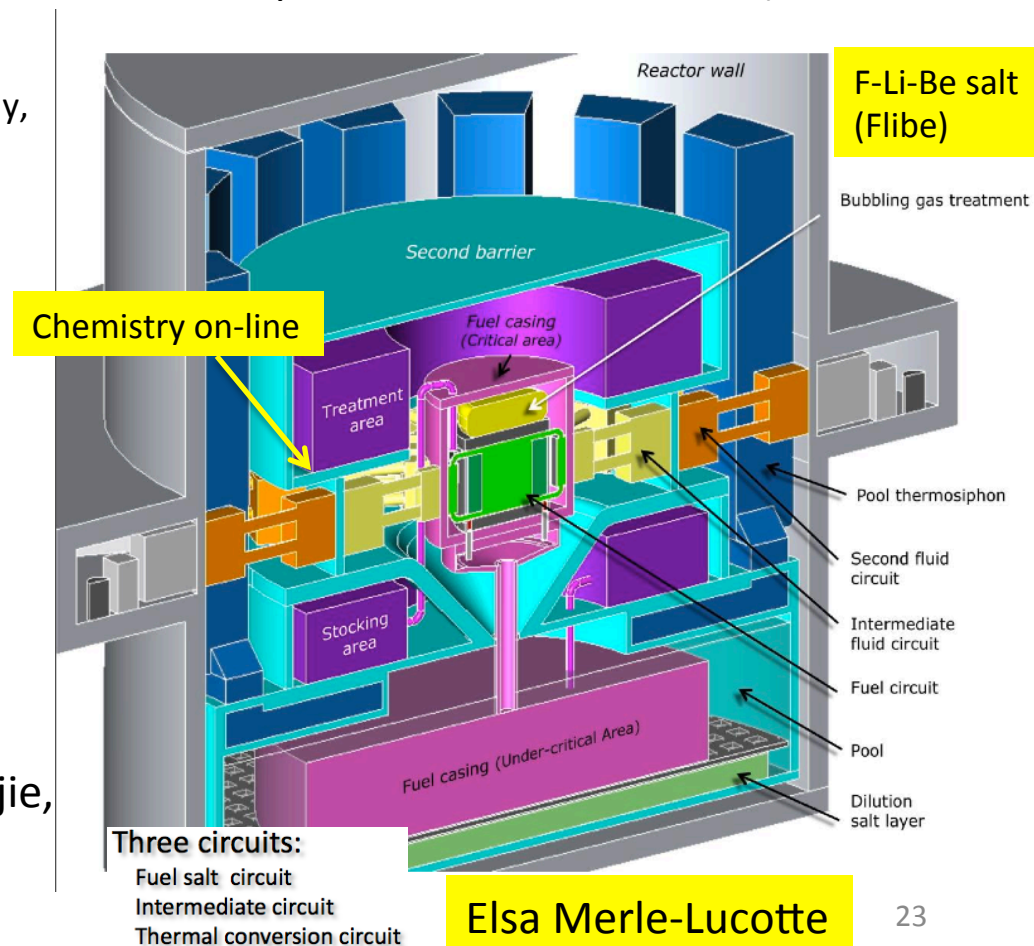

Organizational Overview

The Chinese Academy of Sciences (CAS) and U.S. Department of Energy (DOE) Nuclear Energy Cooperation Memorandum of Understanding (MOU)

MOU Executive Committee Co-Chairs
 China – Mianheng Jiang (CAS) 江绵恒
 U.S. – Peter Lyons (DOE)



Technical Coordination Co-Chairs
 China – Zhiyuan Zhu (CAS) 朱志远
 U.S. – Stephen Kung (DOE)



Nuclear Hybrid Energy Systems *

- Zhiyuan Zhu (CAS) 朱志远
- Yuhuan Sun (SARI, CAS) 孙予罕
- Steven Aumeier (INL)

* Work scope governed by DOE-CAS Science Protocol Agreement

Molten Salt Coolant Systems

- Hongjie Xu (SINAP, CAS) 徐洪杰
- Weiguang Huang (SARI, CAS) 黄伟光
- Cecil Parks (ORNL)
- Charles Forsberg (MIT)



Nuclear Fuel Resources

- Zhimin Dai (SINAP, CAS) 戴志敏

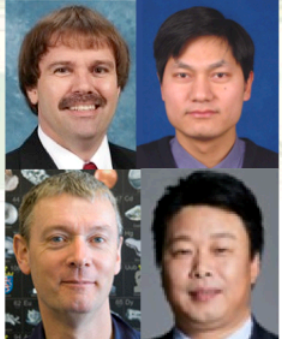

End of March, the Chinese Government decided that the first fully-functioning thorium MSR reactor should be built within ten years, instead of 25 years, as originally planned

SINAP: Shanghai Institute of Applied Physics
 SARI: Shanghai Advanced Research Institute
 ORNL: Oak Ridge National Laboratory
 INL: Idaho National Laboratory
 MIT: Massachusetts Institute of Technology
 UC-Berkeley: University of California at Berkeley

ADS: the subcritical approach

- ❑ A particle **accelerator**, to provide a **neutron source**
- ❑ A **core** in which both source neutrons and fission neutrons are at work – restricted here to the case of a **moderator** allowing for a fast neutron spectrum
- ❑ **Two main areas of physics:**
 - ☞ Neutron production by spallation from the beam
 - ☞ Neutron transport and interaction in the core
- ❑ **Physics also drives other ADS elements:**
 - ☞ Cooling (possibility of natural convection)
 - ☞ Electric power production efficiency (go to highest possible temperature)
- ❑ Physics tested at CERN and well understood
Conceptual phase completed, unlike fusion

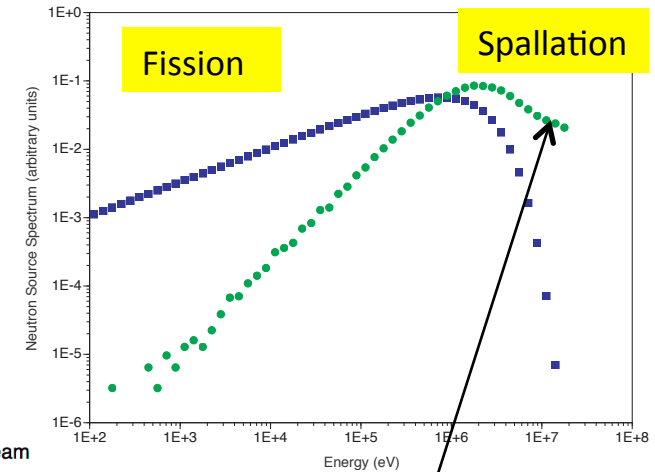

Non negligible contribution from the high energy tail (n, xn) reactions on Pb. See later the effect on k_S

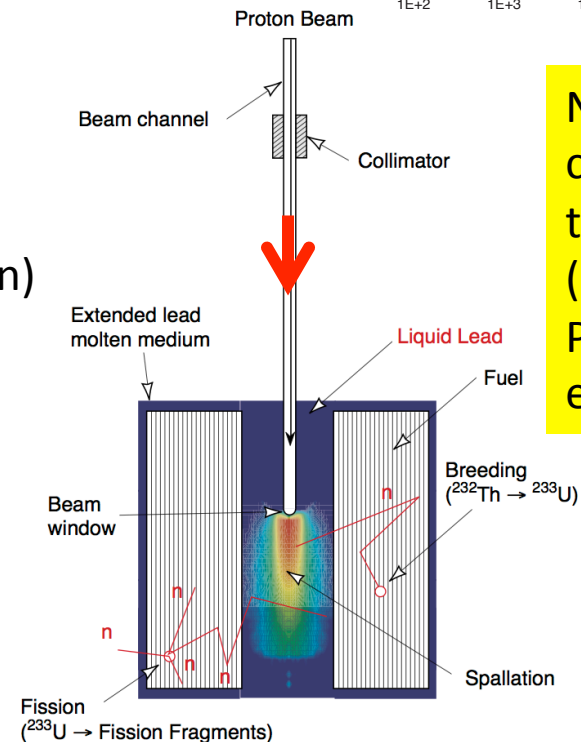

A short history of ADS

□ The basic process in ADS is nuclear transmutation

- ☛ 1919 Rutherford ($^{14}\text{N}_7 + ^4\text{He}_2 \rightarrow ^{17}\text{O}_8 + ^1\text{p}_1$) **^{210}Po accelerator!**
- ☛ 1940 E.O. Lawrence/USA and W.N. Semenov/USSR proposed to use a **particle accelerator as a neutron source**
- ☛ 1942 G. Seaborg produced the **first μg of ^{239}Pu** with the Berkeley 60 inch cyclotron
- ☛ 1950 E.O. Lawrence proposed the **Materials Testing Accelerator (MTA)** at the Lawrence Livermore Radiation Lab, to produce ^{239}Pu from Oak Ridge depleted uranium
- ☛ 1952 W.B. Lewis in Canada proposed to use an accelerator to produce **^{233}U from thorium** for CANDU reactors (electro-breeder concept)



A short history of ADS

- ❑ MTA and Lewis' projects dropped or slowed down when (a) rich uranium deposits were discovered in the USA, and (b) it was realized that it required several hundred mA of beam intensity, hundreds of MW to produce the beam! [*Pu, no amplification*] **today \approx 10 MW beams seem sufficient**
- ❑ Renewed interest in ADS in the 1980's, when the USA decided to slow the development of fast critical reactors (Fast Flux Test Facility @ Argonne National Lab.):
 - ☞ H. Takahashi at Brookhaven National Lab: several proposals of ADS systems (PHOENIX), including the **idea of burning minor actinides** (Fast neutrons – $k_s \approx 0.99$);
 - ☞ Ch. D. Bowman at Los Alamos: thermal neutron ADS (**ATW**) with thorium & chemistry on-line for FP and ^{233}Pa extraction;
 - ☞ Japan launched **Options for Making Extra Gains from Actinides** (OMEGA, now JPARC) at JAERI (now JAEA).

A short history of ADS

- ❑ In the 1990s, Carlo Rubbia gave a big push to the ADS, by launching a vigorous research programme at CERN based on:
 - 👉 development of **innovative simulation** of nuclear systems
 - 👉 specific **experiments to test basic concepts** (FEAT, TARC)
 - 👉 construction of an **advanced neutron Time of Flight facility** (n_TOF) to acquire neutron cross-section data, crucial to simulate reliably any configuration with new materials
- Followed by several proposals for demonstrators



P. Stumpf/SIPA PRESS

C. Rubbia triggered a major R&D effort on ADS worldwide

Carlo Rubbia's Energy Amplifier

- ❑ Proton accelerator driven **subcritical system**:
 - ☛ **Fast neutrons** (10^4 to 10^6 eV range)
 - ☛ Fuel based on **thorium** rather than uranium (minimize waste, less proliferating)
 - ☛ **Lead** as spallation target, moderator and coolant
 - ☛ **Deterministic safety** with passive elements
- ❑ C. Rubbia, et al.
« **Conceptual Design of a Fast Neutron Operated High Power Energy Amplifier** », CERN/AT/**95**-44 (ET)
- ❑ C. Rubbia et al.,
« **A Realistic Plutonium Elimination Scheme with Fast Energy Amplifiers and Thorium-Plutonium Fuel** », CERN/AT/**95**-53 (ET)
- ❑ Jean-Pierre Revol, "An Accelerator Driven System for the Destruction of Nuclear Waste", Progress in Nuclear Energy, Vol. 38, No. 1-2, pp. 153-166, 2001.

jpr/Varenna-2014

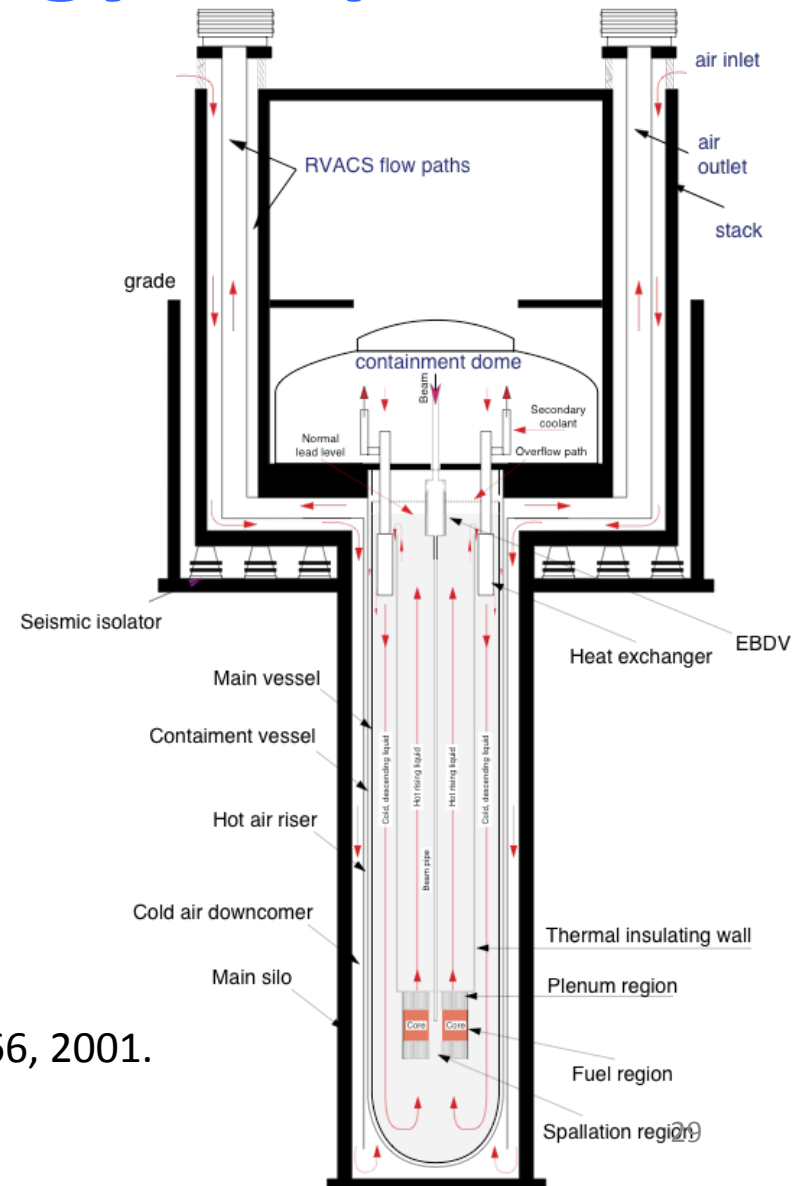

ADS

- ❑ The main issue for ADS today is the absence of a demonstrator. This is much more a political issue (funding) than a scientific one.
- ❑ **The technology for a demonstrator with power of ≈ 100 MWth is ready.**
- ❑ The physics simulation is available – Impressive measurements at CERN n_TOF

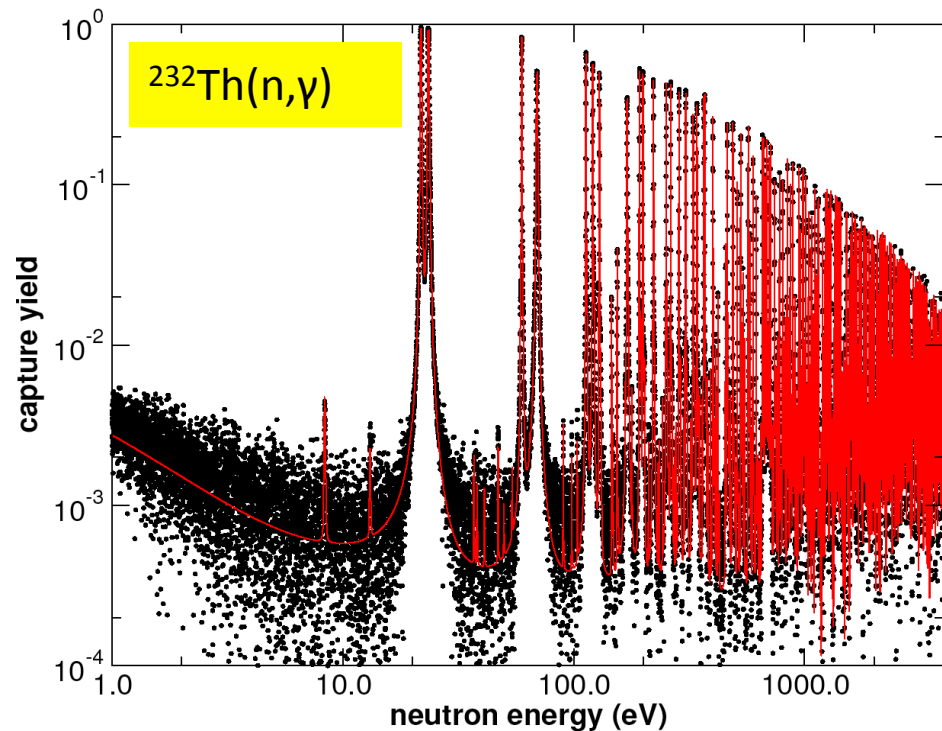

First proposal by C. Rubbia et al., in 1999

Ansaldo engineering design for the Energy Amplifier Demonstration Facility
EA B0.00 1 200 (Jan. 1999)

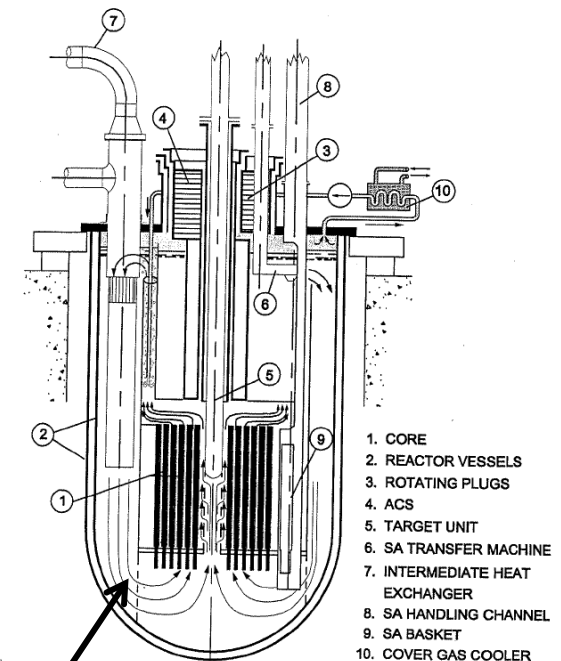

Forced convection

Simplified model of subcritical systems

- ❑ **Theory of subcritical systems** interesting in itself, to get insights into the physics. Properties are quite different from those of critical systems
(*C. Rubbia, CERN/AT/ET/Internal Note 94-036*)
- ❑ Neutron flux geometry important to determine the generated power distribution and the uniformity of fuel burnup
- ❑ Some simplifying assumptions (uniform material and mono-energetic neutrons, small absorption) to get a basic equation similar to that of a critical reactor, but with an **external neutron source term** in addition:

$$\frac{\partial n(\vec{r}, t)}{\partial t} = \nu \sum_f \Phi(\vec{r}, t) + \boxed{C(\vec{r}, t)} - \sum_a \Phi(\vec{r}, t) + D \nabla^2 \Phi(\vec{r}, t)$$

Fission Spallation Absorption Leakage

Simplified model of subcritical systems

- Example of finite system at equilibrium:

$$\frac{\partial n}{\partial t} = 0 \Rightarrow \nabla^2 \Phi + \frac{(k_\infty - 1)}{L_c^2} \Phi = -\frac{C}{D} \quad \text{with } k_\infty \equiv \frac{\nu \Sigma_f}{\Sigma_a}; \quad L_c^2 \equiv \frac{D}{\Sigma_a}$$

Diffusion length

- Two regimes corresponding to two classes of solutions:

- $k_\infty < 1$: the system is intrinsically subcritical (FEAT experiment: $k_\infty \approx 0.93$) – **Solution is an exponential**
- $k_\infty > 1$: subcriticality comes from the lack of confinement, it is a geometrical issue – **Solution is oscillatory** (C. Rubbia's EA: $k_\infty \approx 1.2-1.3$)

$$C(\vec{x}) = D \sum_{l,m,n} c_{l,m,n} \psi_{l,m,n}(\vec{x}) \rightarrow \Phi(\vec{x}) = L_c^2 \sum_{l,m,n} \frac{C_{l,m,n}}{1 - k_{l,m,n}} \psi_{l,m,n}(\vec{x})$$

- All modes are excited
- Important theorem:

$$k_{l,m,n} \equiv k_\infty - L_c^2 B_{l,m,n}^2$$

$$\forall i, k_i < k_1$$

Main results from FEAT

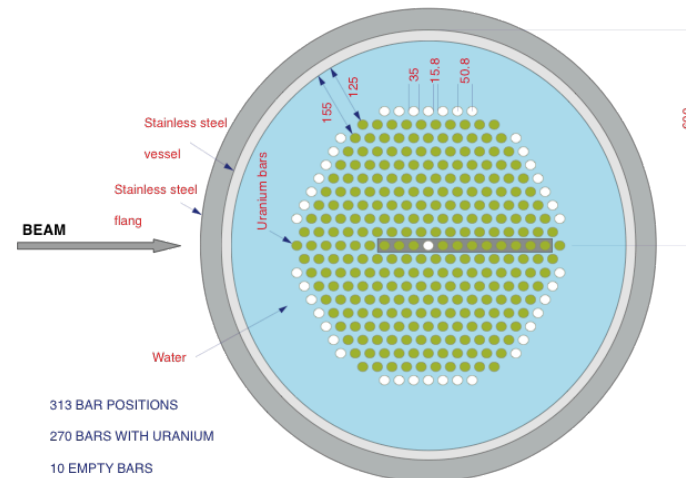
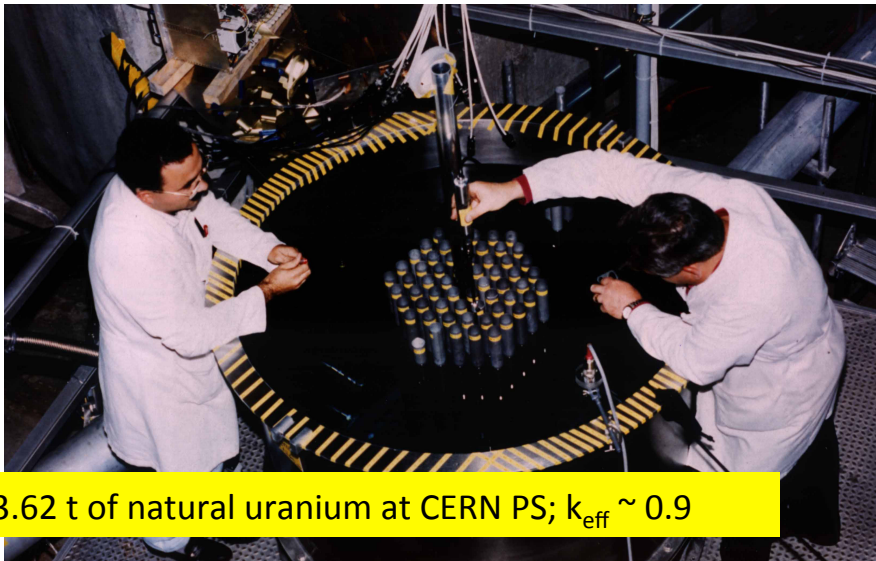
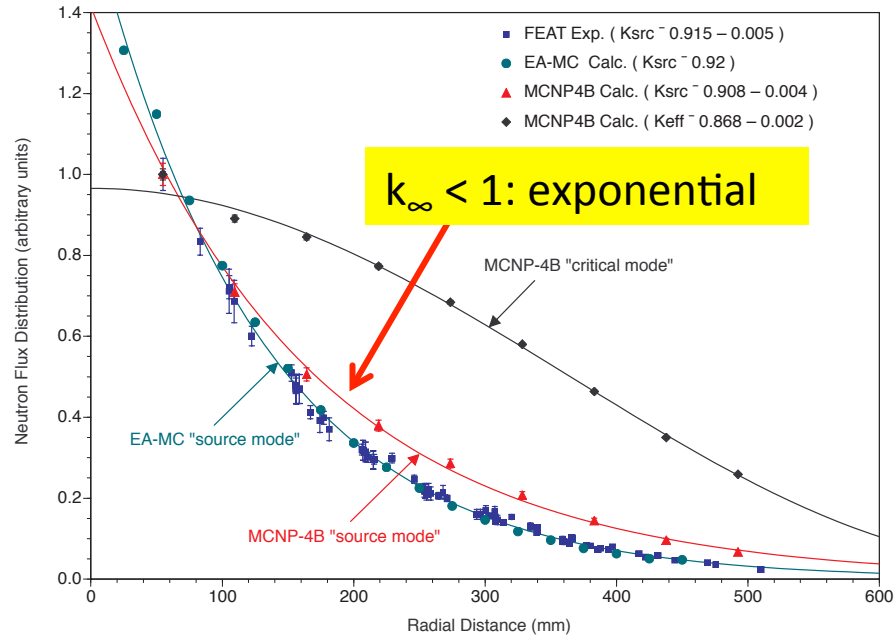

TARC at the CERN PS

- ❑ Neutron phenomenology studies in the TARC experiment at the CERN PS (1996-1997).
- ❑ Testing both the spallation process and neutron transport in lead

Nucl. Instr. Methods Phys. Res., A478 (2002) 577-730

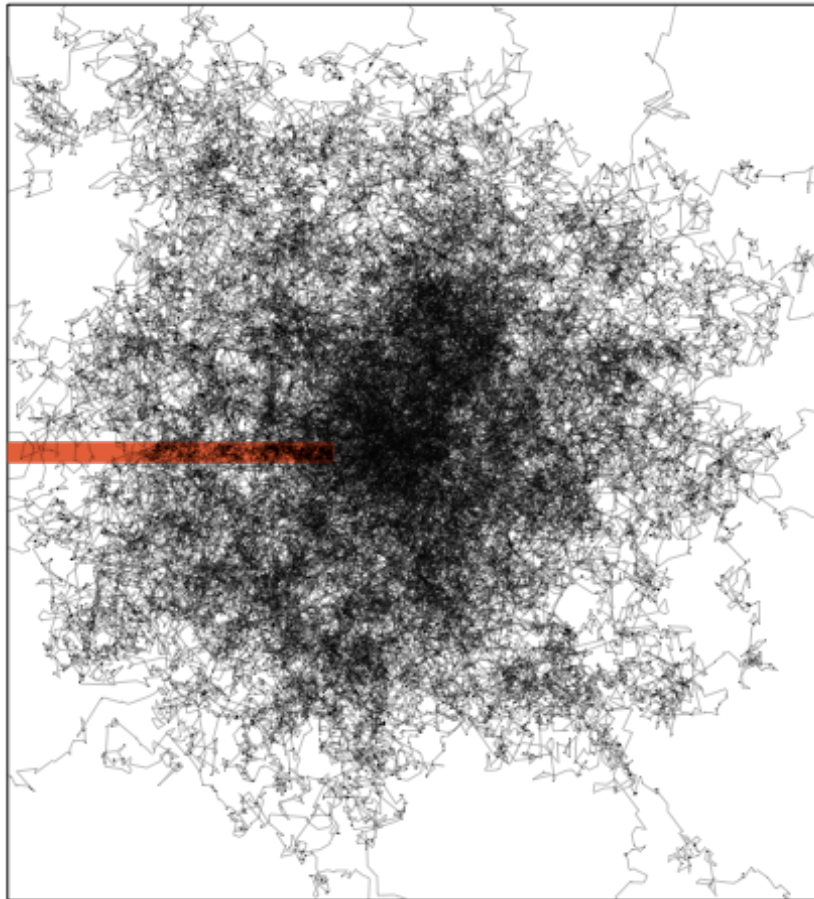

jpr/Varenna-2014



334t of pure lead

Neutron multiplication factor

- The neutron multiplication factor whether the accelerator is on or off:

$$k_{eff} \approx \frac{\overset{\text{Fission}}{\nu \sum_f}}{\underset{\text{Absorption}}{\sum_a} + \underset{\text{Leakage}}{DB^2}}$$

Non-fission multiplication: For fast neutron systems, (n,xn) reactions on Pb are important, in particular for the source neutrons

$$k_s \approx \frac{\overset{\text{Source}}{\nu' \sum_f \Phi(\vec{r}, t) + C(\vec{r}, t)}}{\sum_a \Phi(\vec{r}, t) - D \nabla^2 \Phi(\vec{r}, t)} > k_{eff}$$

Change of flux distribution and multiplication in the source

- Switching off the neutron source not only stops the main power generation, but also moves the system further away from prompt criticality, k_s to k_{eff} .

Physics of subcritical systems

- Subcritical systems are insensitive to delayed neutron fraction (β); **safety margin** (distance from prompt criticality) **is a design choice**, it is not imposed by Nature!
- The reactivity changes only very slowly; the beam can be switched off very quickly, reducing k_s to k_{eff} . It is possible to choose a higher k_s in order to reduce the load on the accelerator (Takahashi at BNL, $k_s = 0.99$)

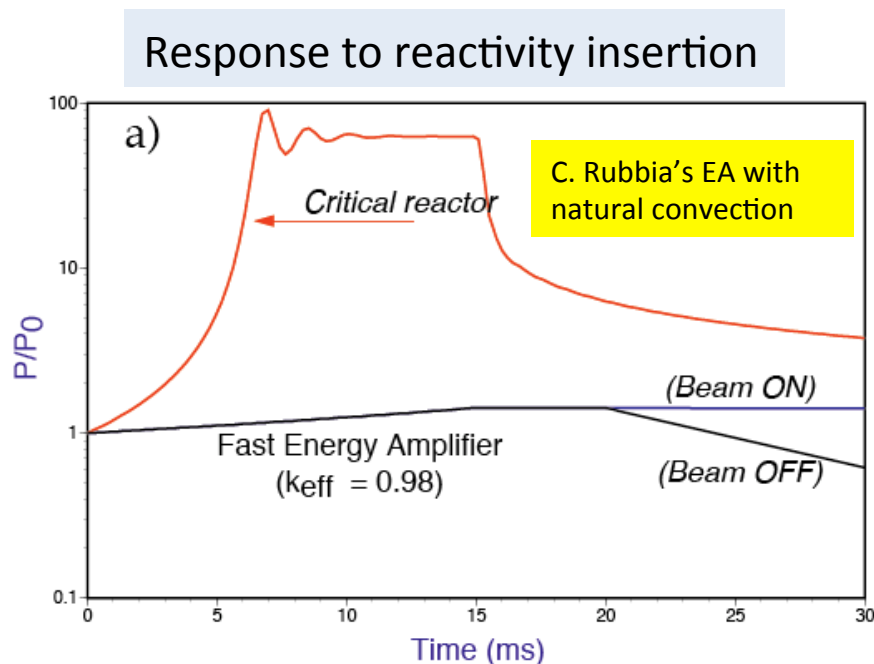

jpr/Varenna-2014

The CERN LHC beam can be switched off in $270\mu\text{s}$, the CERN SPS in $46\mu\text{s}$, and a smaller accelerator for ADS, even much faster. So the reaction time will not be limited by the accelerator. The typically response time of a critical system to reactivity insertion is of the order of 5 ms.

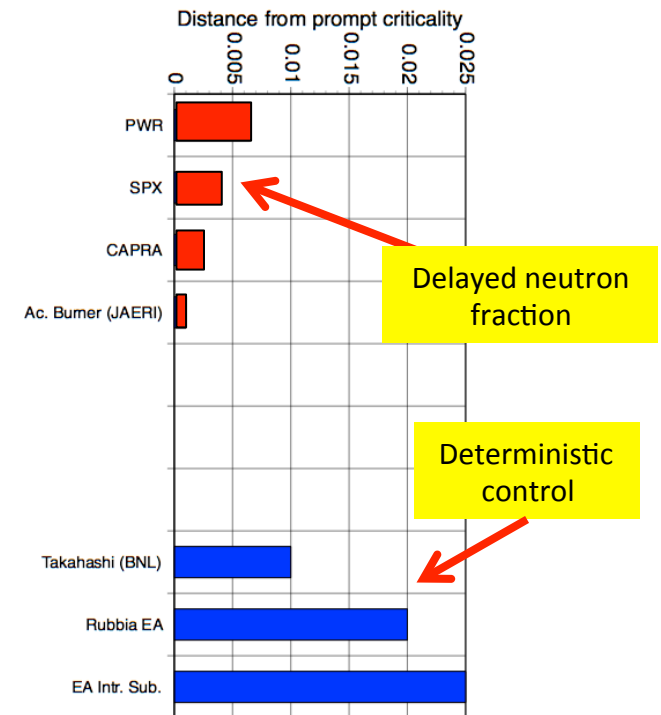

Advantages of ADS

❑ **Safety** – a deterministic as opposed to probabilistic approach:

- ☛ Eliminate criticality accidents by making the system subcritical (void coef., T coef., β_{eff} no longer “critical” parameters)

This requires an external proton source!

- ☛ Operate system with passive safety elements in addition to avoid core melting or limit its consequences, borrowing features from US advanced fast critical reactor designs;
- ☛ Avoid dangerous coolants such as liquid sodium in Generation IV (use lead)

❑ **Waste management:**

- ☛ Use (1) fast neutrons, (2) thorium fuel, and (3) recycle long-lived transuranic actinides (TRU) to minimize waste production or destroy existing waste

❑ **Military proliferation:**

- ☛ Use thorium fuel (very small Pu prod., ^{233}U very difficult mixture)
- ☛ Avoid Pu separation (Purex), use pyro-electro reprocessing instead (developed for uranium at Argonne N.L.)
- ☛ Chemistry on-line in Thorium MSR potentially proliferating (^{233}Pa)

ADS @ ThEC13

- ❑ **Largest number of talks at ThEC13 (17 talks)**
- ❑ **Status of readiness of technologies:**
 - ☛ Accelerator(s) (cyclotrons, linacs, Fixed Field Alternating Gradient)
 - ☛ Spallation targets
 - ☛ Core designs
- ❑ **Presentation of systems:**
 - ☛ MYRRHA (SCK•CEN, Mol, Belgium)
 - ☛ Troitsk (Russia) & CADS (China) for burning minor actinides, and a discussion in India to use ADS to simplify the present thorium utilization scheme
 - ☛ Molten Salt ADS (C. Rubbia, Japan, Korea)
- ❑ **Concrete tests:**
 - ☛ PSI cyclotron beam (1.4 MW proton beam – 2.4 mA x 590 MeV)
 - ☛ 0.8 MW LBE spallation target (MEGAPIE@SINQ (Swiss Spallation Neutron Source), SNS (1.4 mA x 1 GeV, 1.4 MW Spallation Neutron Source at Oakridge N.L.), etc.)
 - ☛ Reactivity measurement by beam pulses (Cheol Ho Pyeon, from Korea)
 - ☛ Corrosion, material compatibility, etc.

MEGAPIE TARGET

Design parameters

p-beam energy: 575 MeV
 p-current: 1.74 mA
 Heat removal: 650 kW
 Design pressure: 16/10 bar
 Design temp.: 400°C
 Cover gas press: 3.2 bar
 Operation: 1 year
 with max 6000 mAh
 Radiation damage: 20-25 dpa

Dimensions

Length: 5.35 m
 Weight: 1.5 t
 LBE-Volume: 89 l

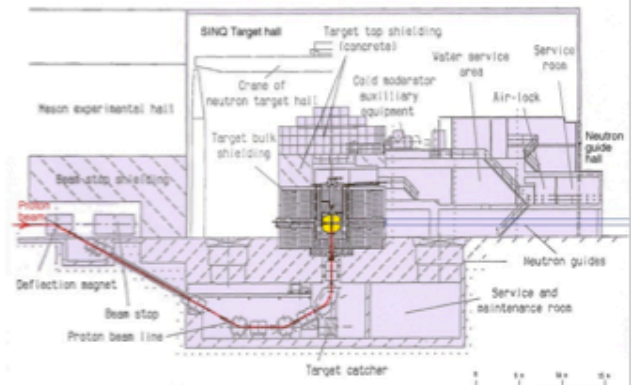
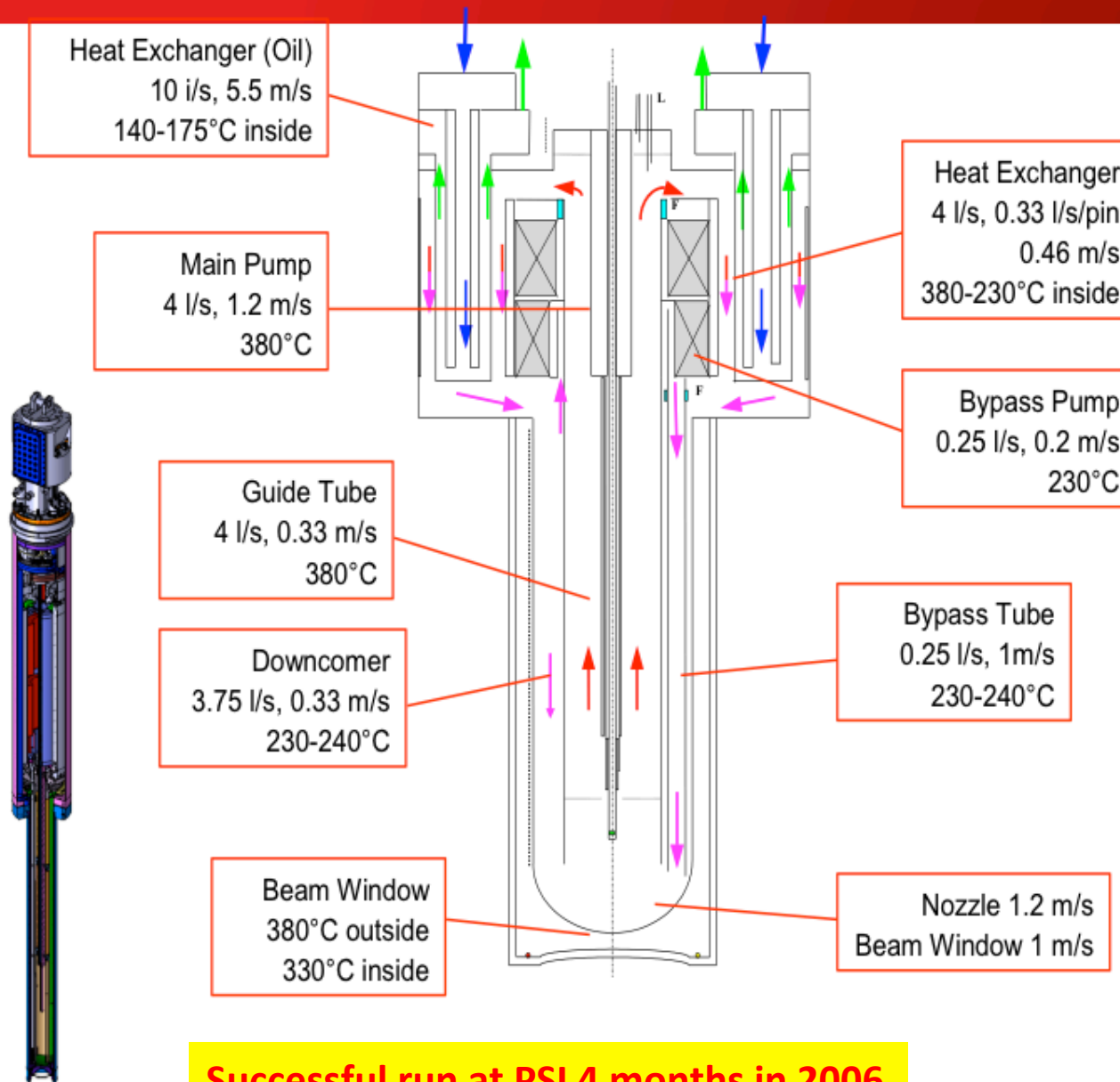

Successful run at PSI 4 months in 2006

Accelerator Driven Systems

MYRRHA - Accelerator Driven System

Most important project in Europe, with strong support from the Belgian government:

- partially funded
- no thorium
- will not remain an ADS, will turn into a critical reactor

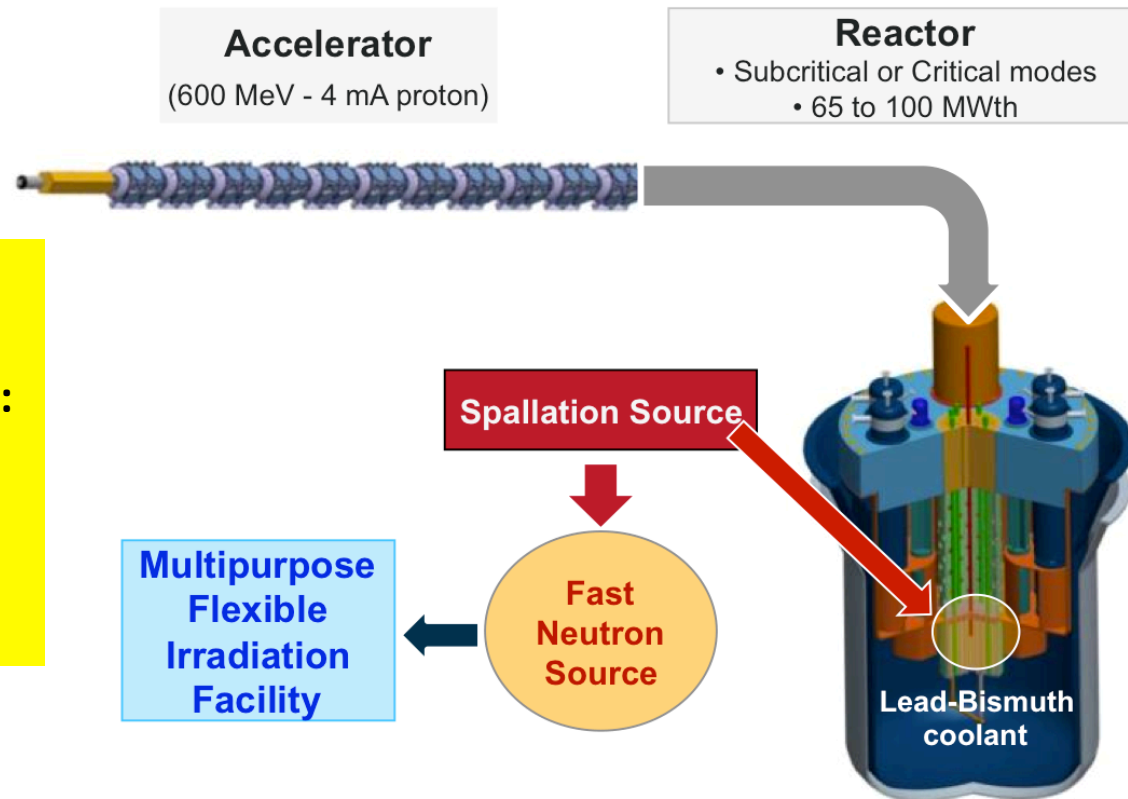

Industrialized ADS

EA Feasibility Study: Aker ASA and Aker Solutions ASA (2010)

- 1500MW_{Th}/600MW_e
- Sub-critical core
- Thorium oxide fuel
- Accelerator driven via central beam tube
- Molten lead coolant
- Coolant temp 400-540°C
- 2 Axial flow pumps
- 4 Annular heat exchangers
- Direct lead/water heat exchange
- *It may be modified to a Minor Actinide burner (ADS)*

CERN_Oct_2013

AkerSolutions

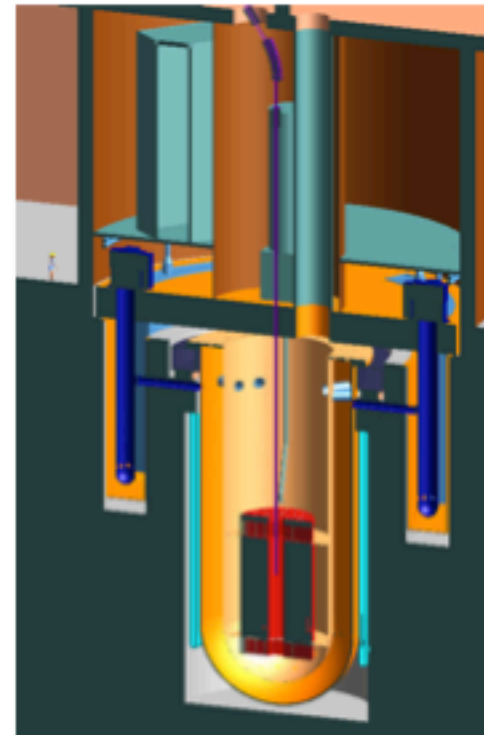

A Thorium fuelled reactor for power generation

Carlo Rubbia

Slide# : 23

Other ADS projects

S. Sidorkin, Russia

China, Japan, Korea, Russia, USA, Venezuela and Ukraine

- 200 kW uranium-based ADS prototype, driven by an electron beam, due for completion in 2014 at the Karkhov Institute of Physics and Technology (KIPT)
- 10 MW **TROISKS** ADS, 300 kW proton beam, rearranging existing elements (accelerator, neutron source, etc.)
- Virginia Nuclear Energy Consortium Authority associated to Jefferson Lab, in the USA, with a view to create a "Science & Technology Center (STC) for the Application of High-Power Accelerators for the Advancement of Innovative Multidisciplinary Science"

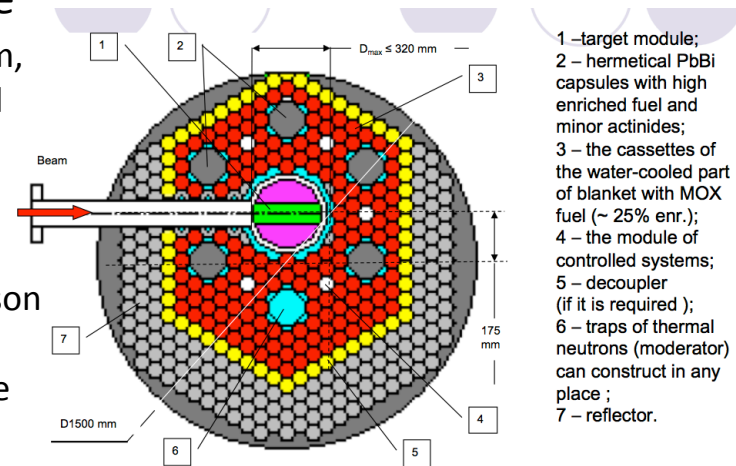

Next ADS Conference

Lack of coordination

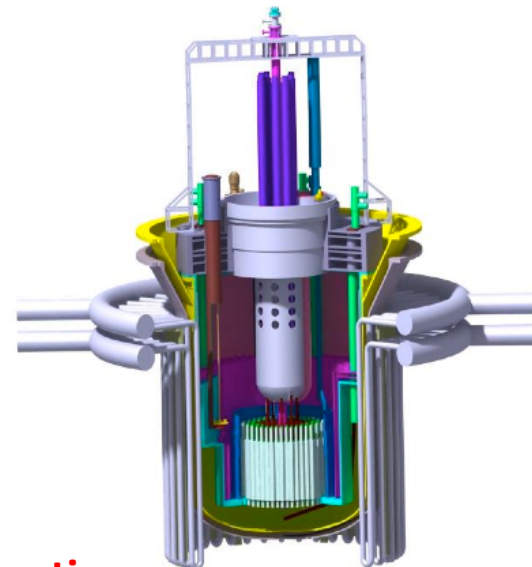

Lei Yang, IMP, China

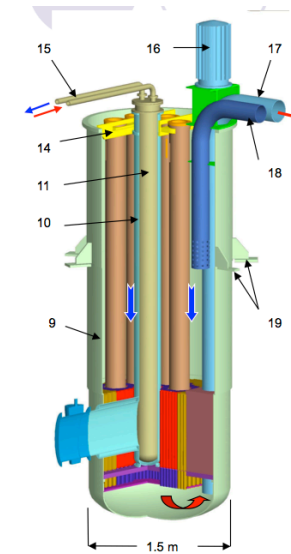

Transmutation performance of ADS

- ❑ **C. Rubbia's EA can destroy** 36 kg of TRU/TW_{th}.h
(A PWR **produces** 14 kg of TRU/TW_{th}.h)

- ❑ Calculations of specific transmutation rates (Y. Kadi)

Transmutation rates (kg/TW_{th}.h) of plutonium and minor actinides and LLFPs

Nuclides	EADF (ThPuO ₂) ENDF/B-VI	EADF (UPuO ₂) ENDF/B-VI	EADF (UPuO ₂) JENDL-3.2	PWR (UO ₂)
²³³ U	+ 31.0			
Pu	- 42.8	- 7.39	- 5.55	+ 11.0
Np	+ 0.03	+ 0.25	+ 0.24	+ 0.57
Am	+ 0.24	+ 0.17	+ 0.14	+ 0.54
Cm	+ 0.007	+ 0.017	+ 0.020	+ 0.044
⁹⁹ Tc prod	+ 0.99	+ 1.07	+ 1.22	+ 0.99
⁹⁹ Tc trans	- 3.77	- 3.77		
¹²⁹ I prod	+ 0.30	+ 0.31		+ 0.17
¹²⁹ I trans	- 3.01	- 3.01		

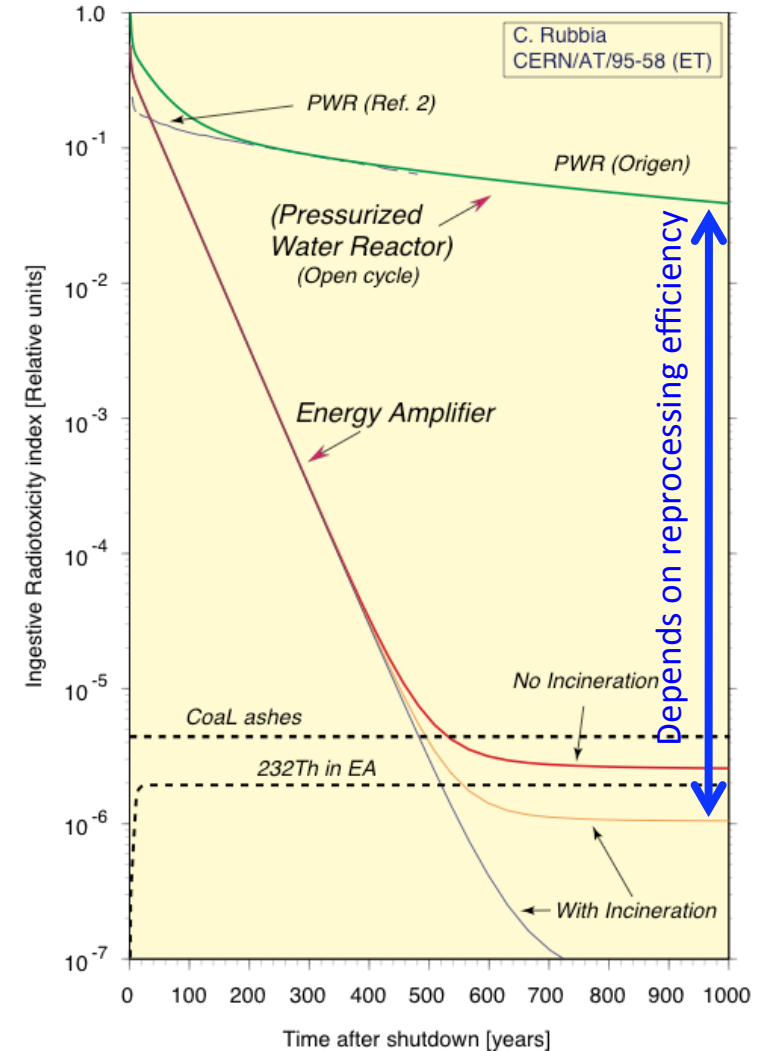

ADS energy gain

- A source neutron is multiplied by fissions and (n,xn) reactions. Since $k_s < 1$, neutron production stops after a limited number of generations:

$$N_0 (1 + k_s + k_s^2 + k_s^3 + k_s^4 + \dots + k_s^n) = N_0 M = N_0 \frac{k_s^{n+1} - 1}{k_s - 1} \approx \frac{N_0}{(1 - k_s)}$$

- The energy gain G is a characteristic of ADS:

$$G \equiv \frac{\text{Energy produced in EA}}{\text{Energy injected by the beam}} = \frac{\overset{\text{Energy/fission}}{0.18k_s N_0}}{\underset{\text{n/fission}}{\gamma(1-k_s)E_b}} = \frac{\overset{\text{n/p}}{G_0 k_s}}{\underset{\text{Beam energy}}{(1-k_s)}} \approx \frac{G_0}{(1-k_s)}$$

- G_0 includes information from the spallation process ($G_0 \sim 3$ for uranium; $G_0 \sim 2.7$ for lead, etc.)

$$G = \frac{G_0 (E_b, \text{Material}, \text{Geometry})}{1 - k_s}$$

Main results from FEAT

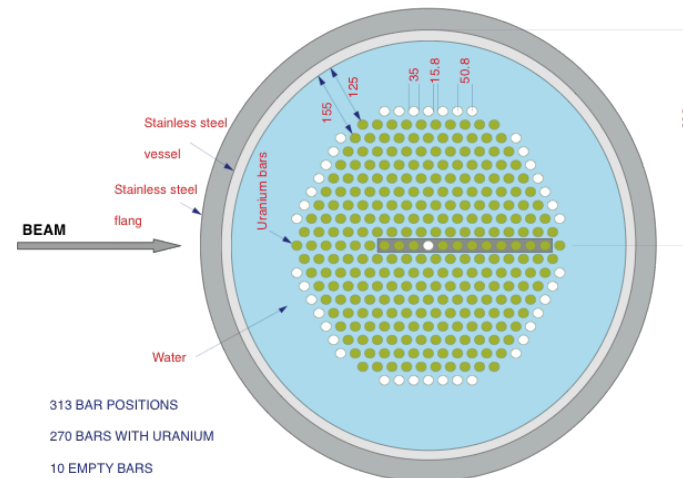
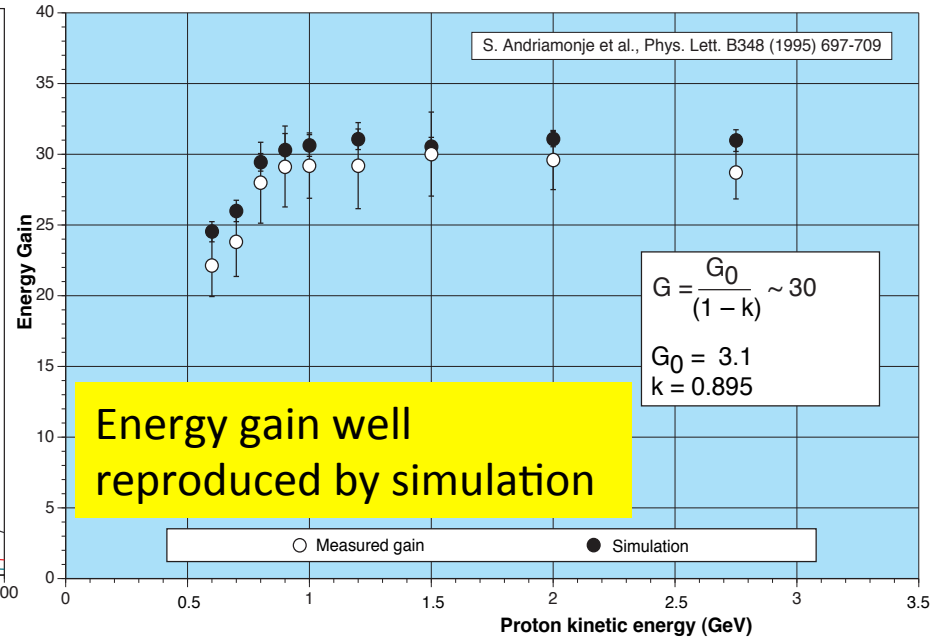
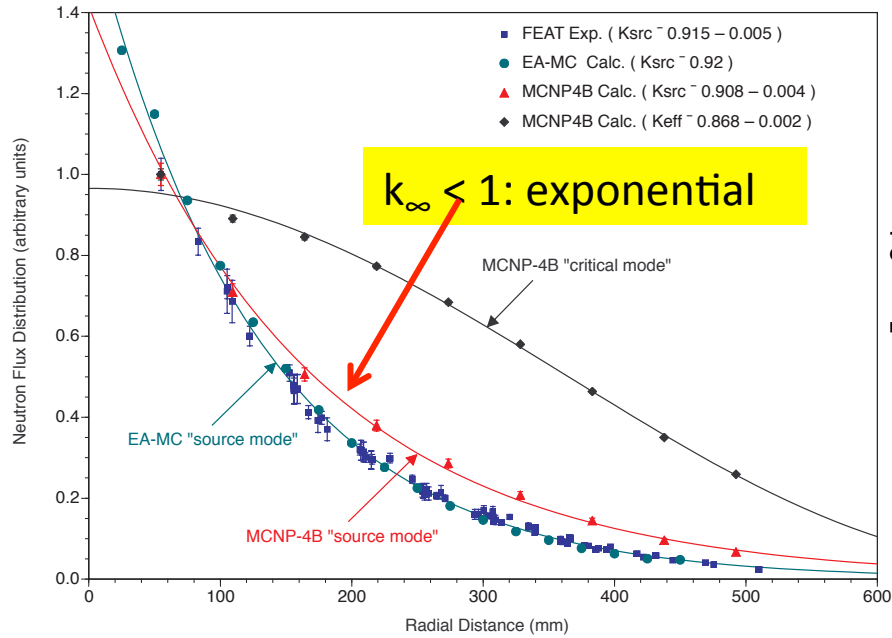

Energy gain in ADS systems

- For a given power output, the energy gain (choice of k_s and G_0) determines the accelerator power
- Trade-off between accelerator power and criticality margin**
- Possibility of modulating the beam intensity to allow variations in the power output (**complementary with a fluctuating renewable energy source**)
- Neutronics with thorium very favourable compared to uranium** $t_{1/2}$ (^{233}Pa) $\sim 27\text{d}$; $t_{1/2}$ (^{239}Np) $\sim 2.3\text{d}$! What was a problem in the use of thorium in critical reactors becomes an advantage in the case of ADS

$$P_{beam} = \frac{(1 - k_s)}{k_s G_0} P_{ADS}$$

Margin of present PWR

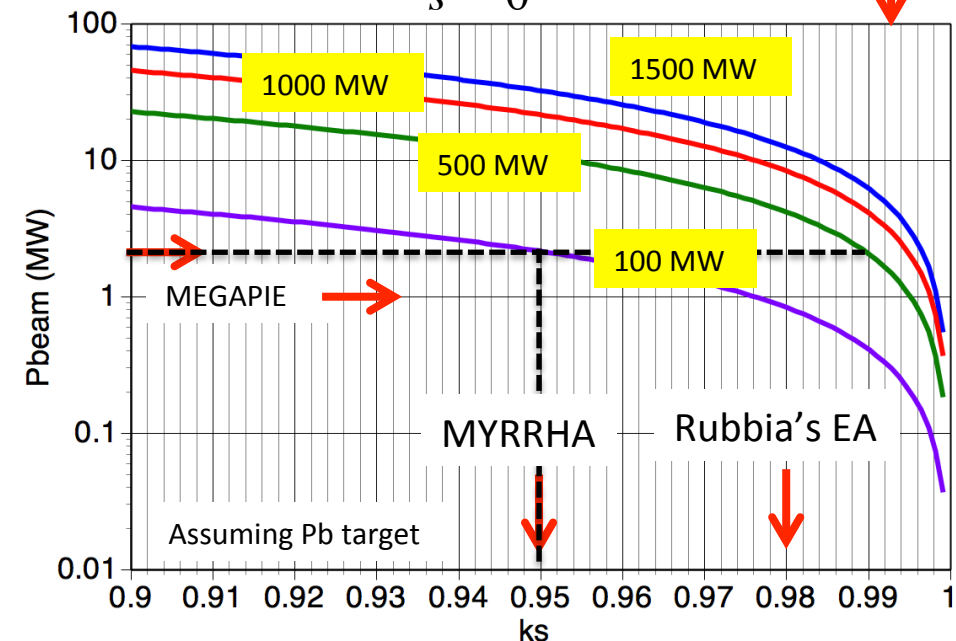

PSI separate turns cyclotron

(2.4 mA and 1.4 MW, with 0.59 GeV protons).

$P_{ADS} = 210 \text{ MW}_{th}$ with $k = 0.98$

MYRRHA LINAC

(≤ 1 to 4 mA and ≤ 2.4 MW, with 0.6 GeV protons)

$P_{ADS} = 50\text{-}100 \text{ MW}_{th}$ with $k = 0.95$

Accelerator requirements

- In principle, it does not matter how the external neutron source is provided. In practice, for industrial applications, there are a number of well-defined requirements for the accelerator:
 - ☛ **Beam particle: protons**
 - ☛ **Beam power: a few to ≈ 10 MW** depending on choice of ks value, and power output
 - ☛ **Beam Energy: $E_{\text{beam}} \geq 800\text{-}900$ MeV**
 - ☛ **Beam spot size (footprint):** large on impact on window (studies at JAEA: $OK \leq 0.1\text{-}0.2$ mA/cm²), MYRRHA has 0.07mA/cm²)
 - ☛ **Beam losses:** minimize irradiation of the accelerator and of the environment (main issue for any high power beam, not only for ADS); impact on the maintenance and repair
 - ☛ **Reliability:** minimize beam trips (multiple sources); the limitation comes mainly from thermal stress in fuel structure. For instance, for MYRRHA:
 - Trip < 0.1 s no limit
 - 0.1 s < Trip < 3 s not more than 100 per day
 - Trip > 3 s 10 in three months
 - Administrative limit if SCRAM event
 - ☛ **Beam power stability and control:** 1% fluctuation on beam intensity is 1% fluctuation on the thermal power

Accelerator requirements

- ▶ **Large operational range of beam intensity:** to follow demand (factor 10?)
- ▶ **Energy efficiency:** maximize fraction of electric grid power stored in the beam. Relevant to overall energy efficiency of system
- ▶ **Size of accelerator:** for waste elimination, people might want to fit it on the site of a standard nuclear power plant
- ▶ **Cost:** This is very important. One main criticism of ADS is that “the accelerator does not exist and will be too expensive”

□ In the end, the solution chosen among LINAC, Cyclotron or FFAG, will be the one best fulfilling these requirements

Separate turn Cyclotron

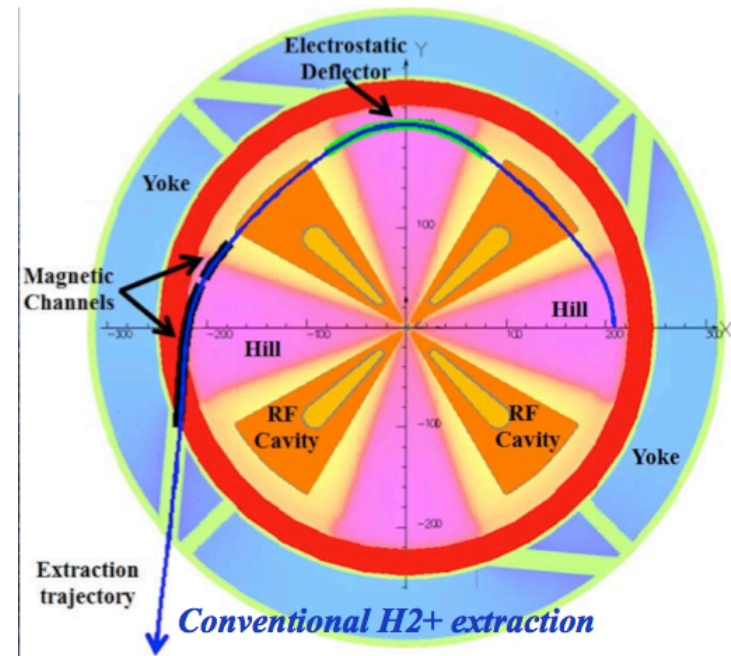

H₂⁺ AIMA Cyclotron w reverse bend and multiple injection, 1.6 MW at 800 MeV (P.Mandrillon)

Superconducting SNS LINAC

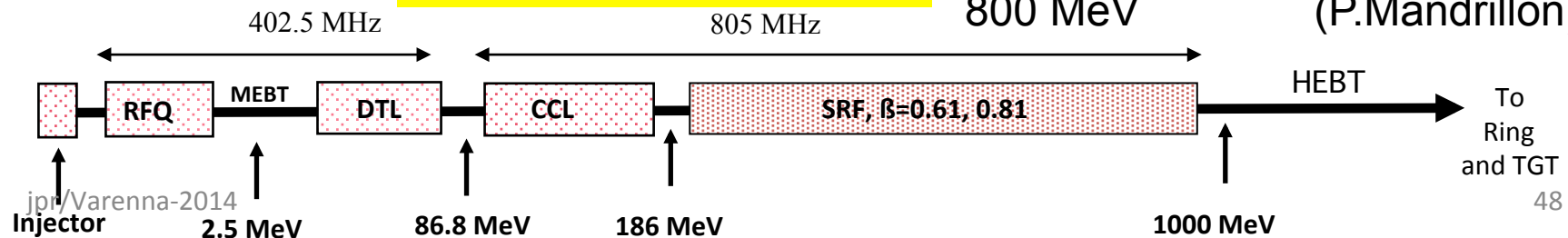

Conclusion

- ❑ There is no reason to keep thorium out of the energy R&D effort in Europe. Furthermore Europe has all the know-how to do this efficiently.
- ❑ **The physics of Accelerator-Driven Systems is well understood, conceptual designs exist.**
- ❑ When taking into account the need for safety, waste management and non-proliferation, thorium in a fast neutron ADS, is an interesting option for energy production and waste elimination.
- ❑ It is a challenging innovation but there is no show stopper. Europe cannot afford not to built a “demonstrator” of significant power (MYRRHA?) in order to validate technological solutions.
- ❑ iThec in Geneva is promoting R&D on thorium in general, and on ADS in particular:
<http://www.ithec.org/>



Xu Hongjie

Anil Kakodkar

Thank You!

India – Vast Resources of beach sand minerals (Ilmenite, monazite, zircon)



P.K. Wattal
BARC, India

RESERVE

Results from TARAC

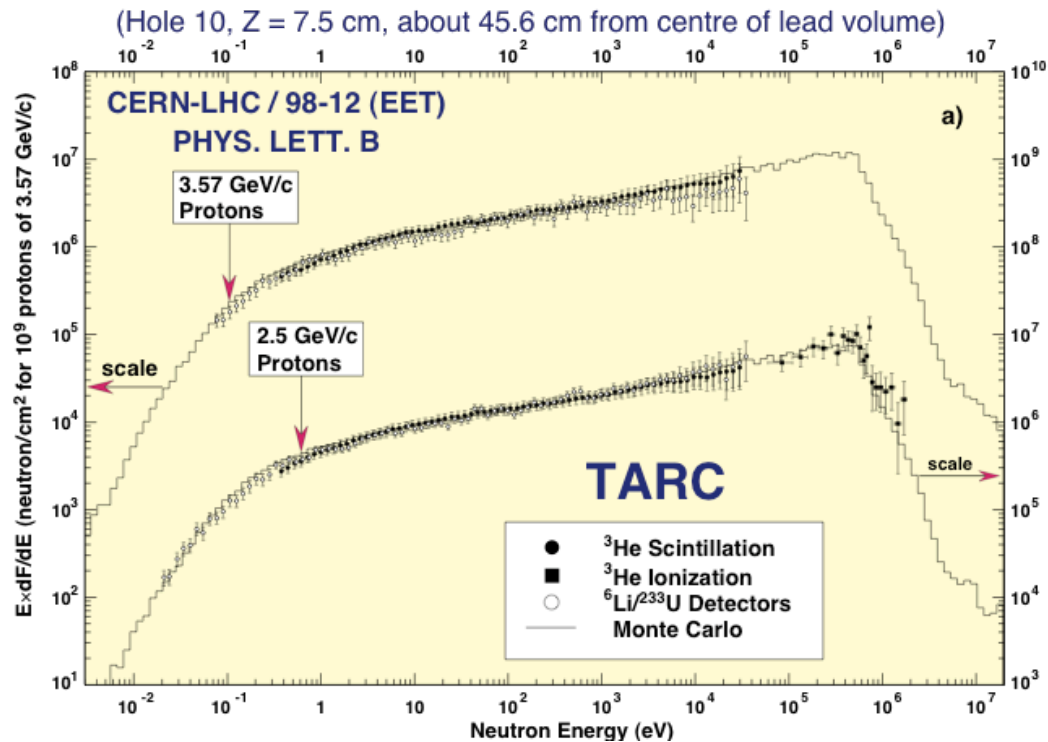

- Demonstrated **Adiabatic Resonance Crossing** for the elimination of long-lived fission fragments, an idea also proposed by C. Rubbia.

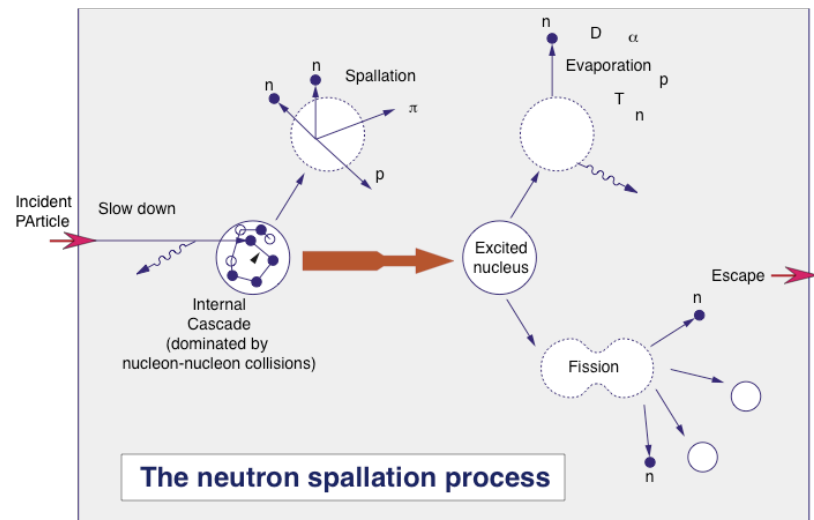
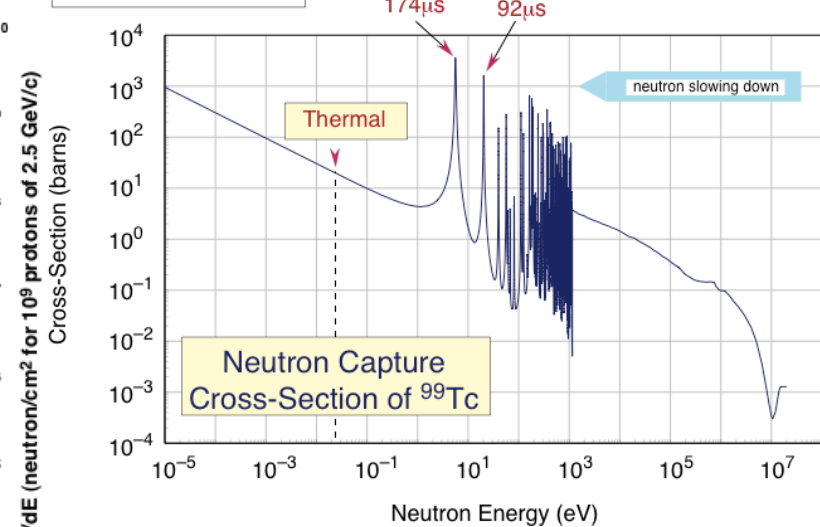
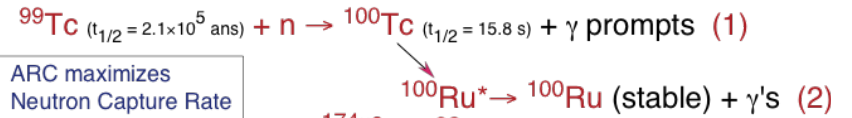

Time dependence

- Diffusion equation (with $\Phi = \beta n$, where β is the neutron velocity):

$$\frac{\partial n(\vec{x}, t)}{\partial t} = \frac{1}{\beta} \frac{\partial \Phi(\vec{x}, t)}{\partial t} = D \nabla^2 \Phi(\vec{x}, t) + (k_\infty - 1) \Sigma_a \Phi(\vec{x}, t) + C(\vec{x}, t)$$

- Case of a neutron pulse, given by $C_0 \delta(t)$, and substituting

$$\Phi(\vec{x}, t) = \sum_{l,m,n} \Phi_{l,m,n} \psi_{l,m,n}(\vec{x}) f_{l,m,n}(t)$$

provides an equation for the time dependence:

$$\frac{df_{l,m,n}(t)}{f_{l,m,n}(t)} = -\beta \left[DB_{l,m,n}^2 + (1 - k_\infty) \Sigma_a \right] dt$$

and the general solution

$$\Phi(\vec{x}, t) = \sum_{l,m,n} \Phi_{l,m,n} \psi_{l,m,n}(\vec{x}) e^{-\beta \Sigma_a (1 - k_{l,m,n}) t}$$

- Characteristic decay time is shorter as modes become higher. At the criticality limit ($k_{1,1,1} = 1$), the mode is infinitely long. Fermi used this to measure the approach of criticality in his Chicago Pile 1 in 1942, and the method is well suited for ADS.

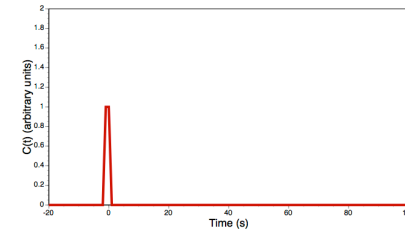

Fossil Fuel Proven Reserves

- Newly discovered resources are also getting more expensive to extract

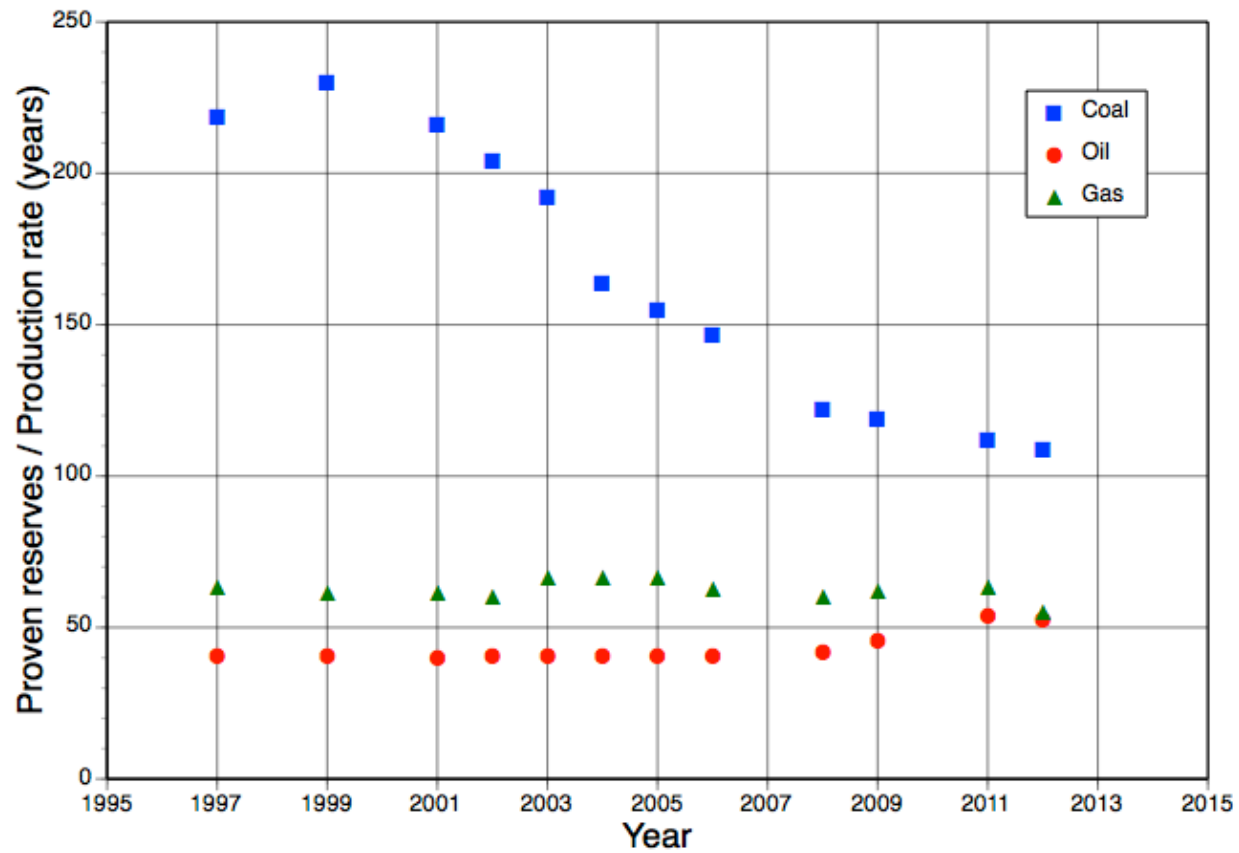

Energy and pollution in China

- ❑ Even though coal accounts for 70% of China's total energy consumption, China is doing better than most European countries, in terms of CO₂ emissions: no point telling China to stop burning coal ...

Country	ton of CO ₂ per capita
USA	16.94
Germany	9.14
Denmark	7.48
→ China	5.92
France	5.04
World	4.50

Source:
IEA 2013
Key World
Energy Statistics

- ❑ Germany to open 10 new coal-fired power stations in the next two years (Blomberg, Nov. 2013), while at the same time exporting subsidized green electricity (Netherland)

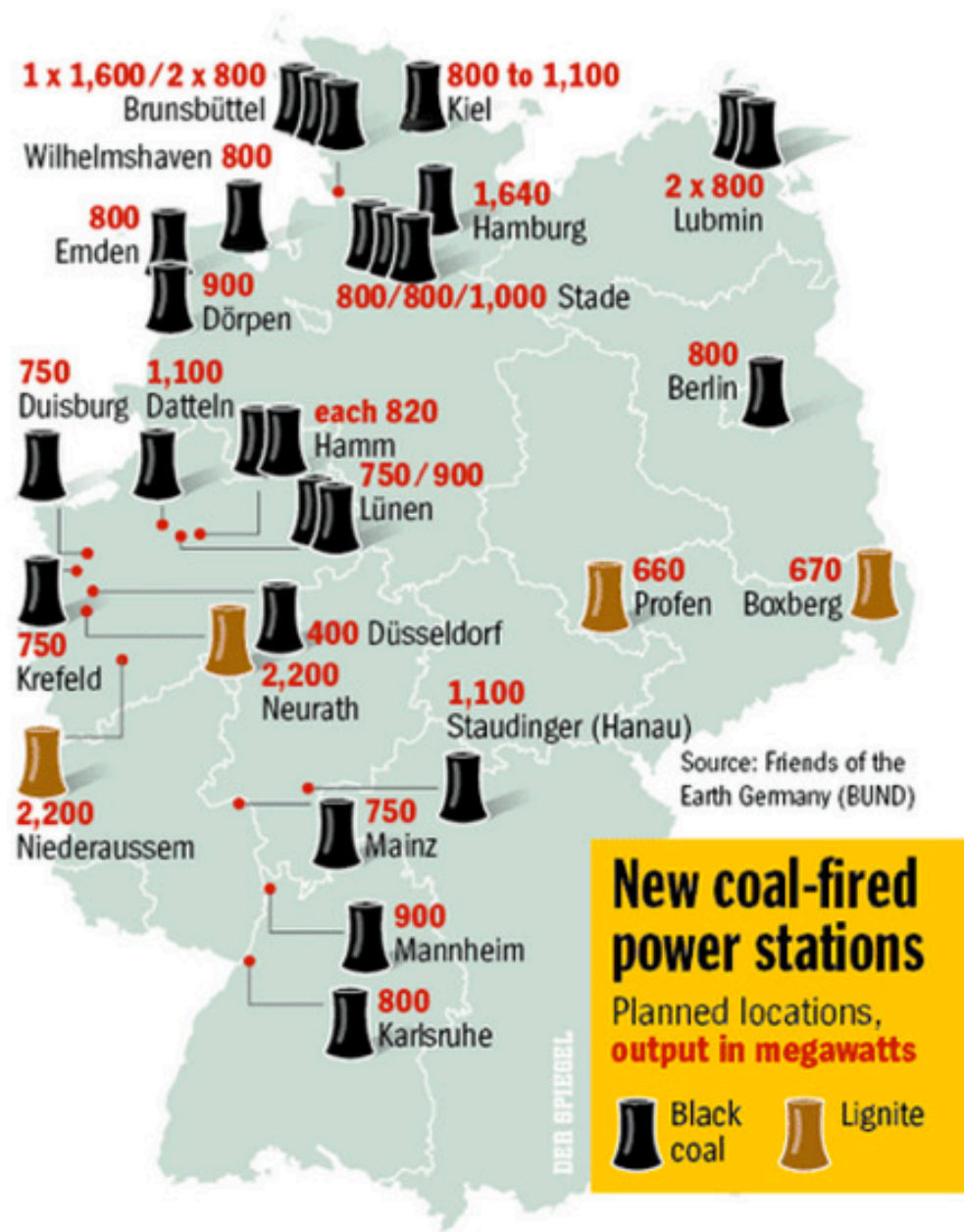

[MYRRHA home](#) » [Engineering](#) » [Accelerator](#) » Linac versus cyclotron

- MYRRHA »
- Engineering** »
- R&D programme »
- Media gallery »
- Publications
- ISOL@MYRRHA

Choice of the accelerator type: Linac versus cyclotron

In principle both accelerator types can deliver the required proton beam for ADS applications. However, the nature of each — one compact unit for an isochronous cyclotron, a sequential modular structure for the linac — brings both advantages and disadvantages.

Due to its recirculation nature, a cyclotron is compact and cost effective. However, it lacks every form of redundancy which is crucial for fault tolerance. Hence, a cyclotron will not reach the wanted level of [availability](#), and furthermore an upgrade of its beam energy is not a realistic option.

Linacs on the other hand, can be built as a sequence of many independent accelerating structures (RF cavities), which is a highly modular situation. It is this modularity that makes such a linac particularly well suited to tackle the availability issue. In case of failure of a single accelerating module, independently controlling the RF amplitude and phase of the adjacent modules creates the conceptual possibility of recovering the beam within a short time. Furthermore, increasing the final beam energy is obtained by merely adding accelerating modules.

For these reasons [MYRRHA favours the linac option](#).

Linac versus cyclotron

LINAC	CYCLOTRON
Large space requirement (few hundred m long) but light	Compact but heavy
Expensive	Cheaper in construction
Less efficient power conversion	More efficient power conversion
Modularity provides redundancy	No intrinsic redundancy
Upgradable in energy	Difficult to upgrade in energy
Straightforward beam extraction	Difficult extraction and related beam losses
Capable of high beam current (100 mA)	Modest beam current capability (5 mA)

Realistic ADS system

Energy Amplifier Conceptual Design
C. Rubbia, et al., CERN/AT/95-44 (ET)

Ansaldo Engineering design
for the Energy Amplifier
Demonstration Facility
EA B0.00 1 200 (Jan. 1999)

Natural convection

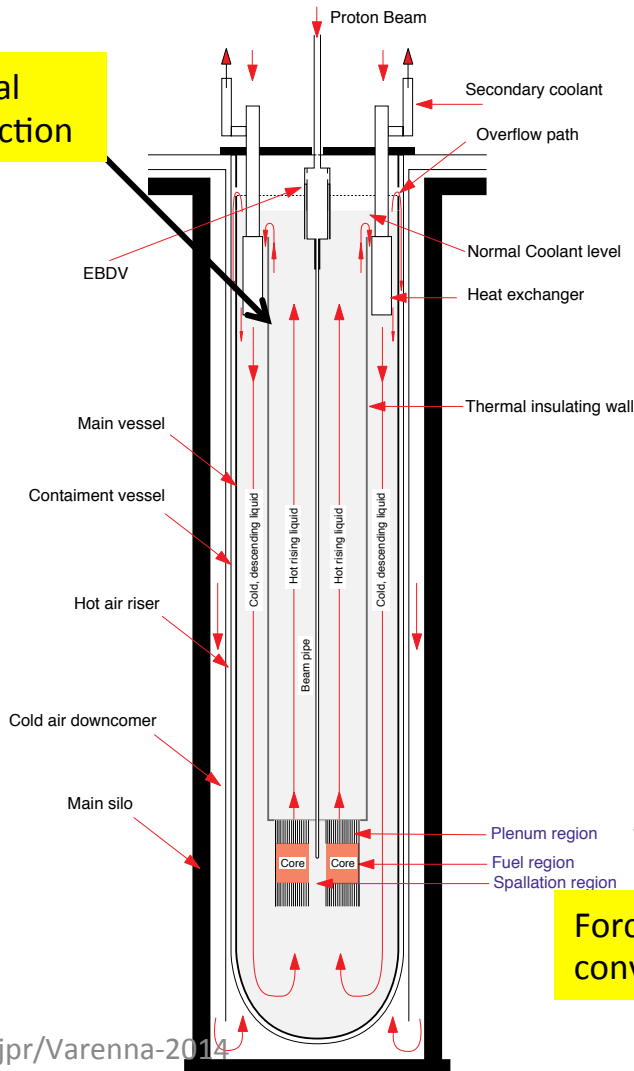

Forced convection

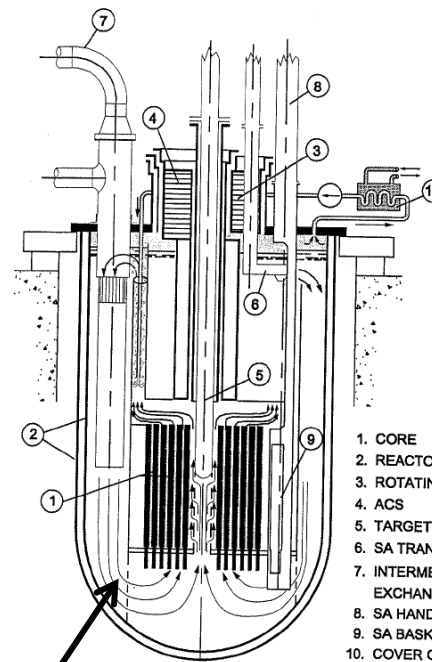

- ❑ Today one can simulate in great detail any realistic system of this type (LHC experiments have up to 30 million volume elements in their simulation)
- ❑ The physics is extremely well known!
- ❑ Use passive safety – physics does not fail!
- ❑ Neutron data are improving

Simulation never better than the quality of input data :
Strategic importance of n_TOF at CERN!

Neutron cross section data

❑ Develop precise and predictive simulation, requires precise input data:

👉 n_TOF facility at CERN

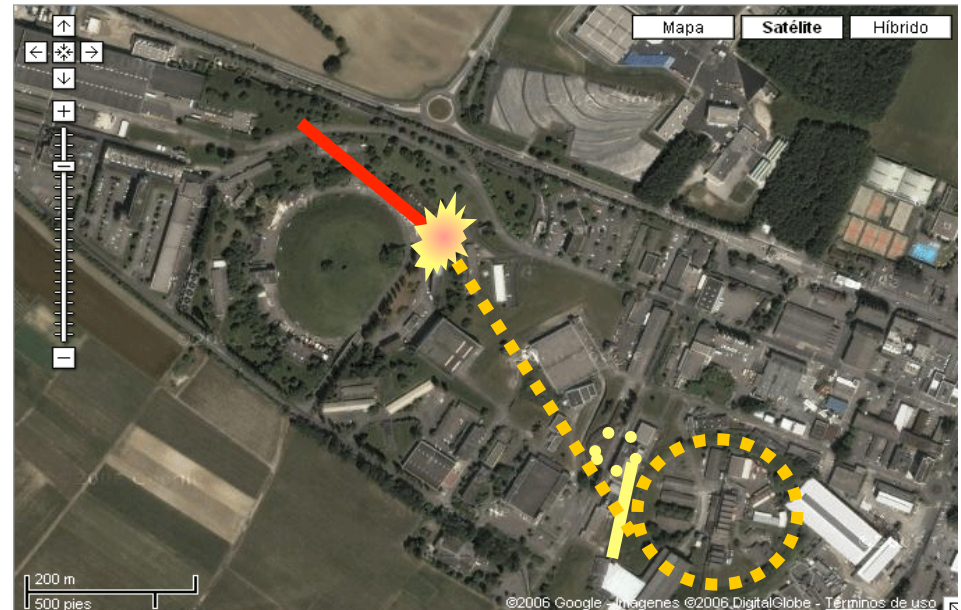
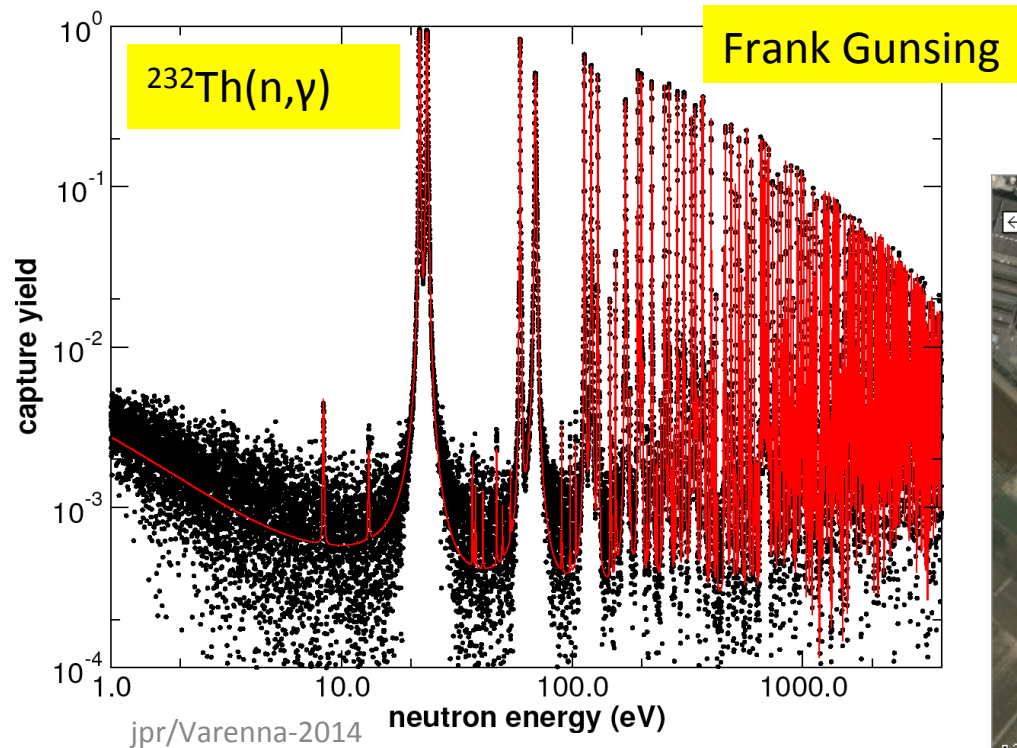
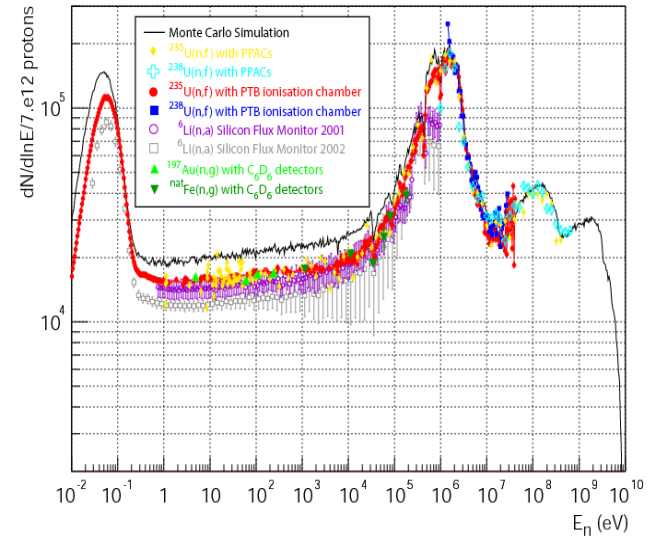

The energy problem

- ❑ If the rest of the world is allowed to live as well as we do in Europe today, then the energy production of the world will have to be increased by a factor of 3 or more, by the end of this century, when the world population will likely approach 11 billion individuals (from 15 TW to ≥ 50 TW). Most of the population increase is expected in developing countries. **Europe is not representative of the world!**

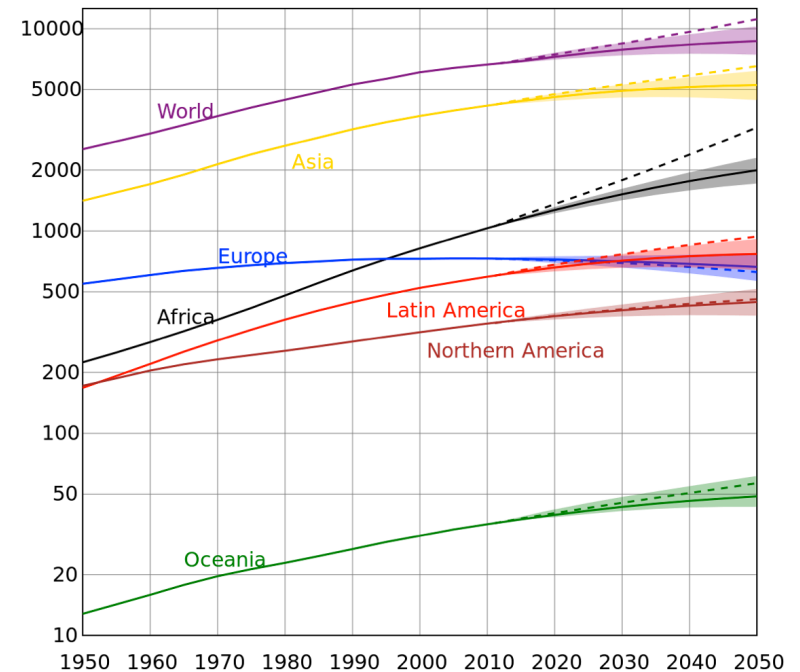
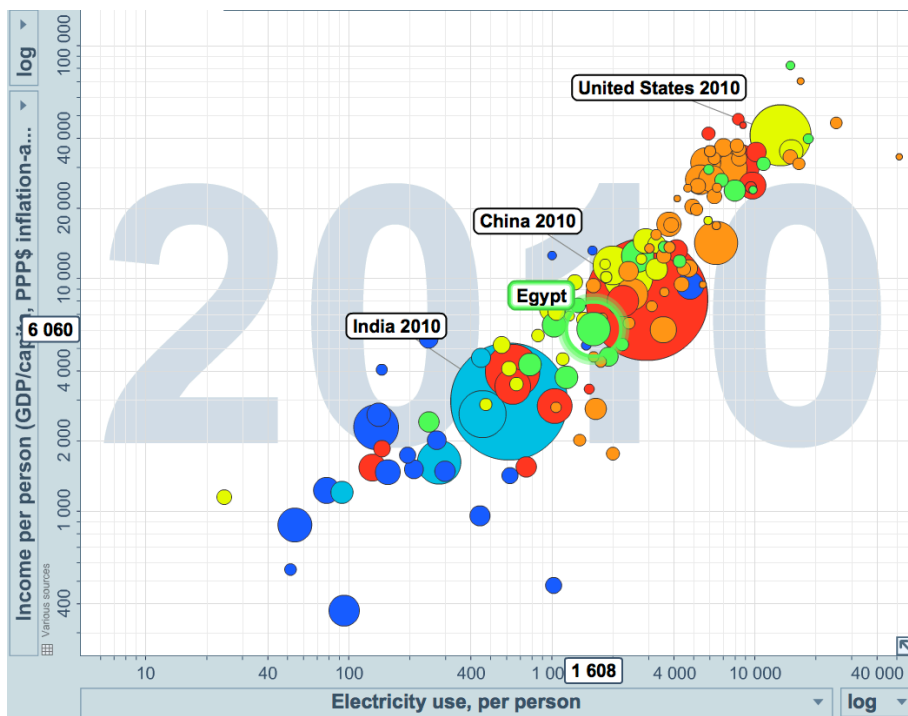

“Visualization from **Gapminder World**, powered by Trendalyzer from www.gapminder.org.”

See Prof. Hans Rosling’s lecture 61

Architecture of an ADS system

- Example of the generic 1500 MW_{Th} system (Energy Amplifier), designed and simulated by C. Rubbia et al. (CERN/AT/95-44 (ET))

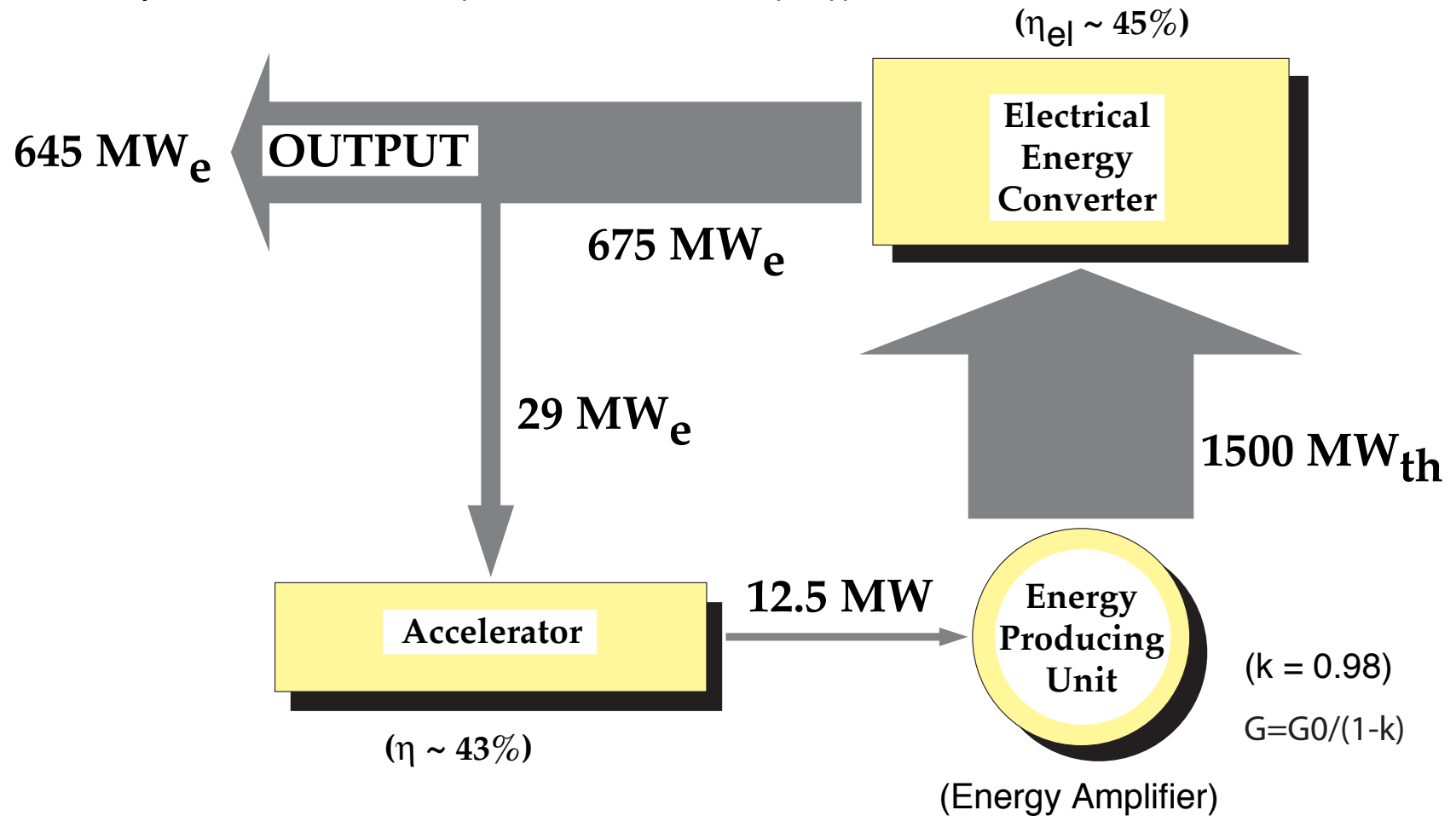

Critical versus Subcritical Systems

Chain Reaction

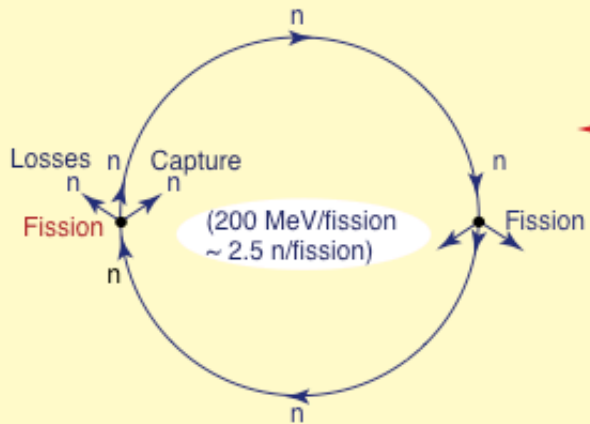

Critical Reactor

Effective neutron multiplication factor

$$k = \frac{\text{Production}}{\text{Absorption} + \text{Losses}}$$

Self-sustained process:
 $k = 1$
 (if $k < 1$ the Reactor stops
 if $k > 1$ the Reactor is supercritical)

⇒ The time derivative of the power kept equal to zero by control

Nuclear Cascade

Energy Amplifier

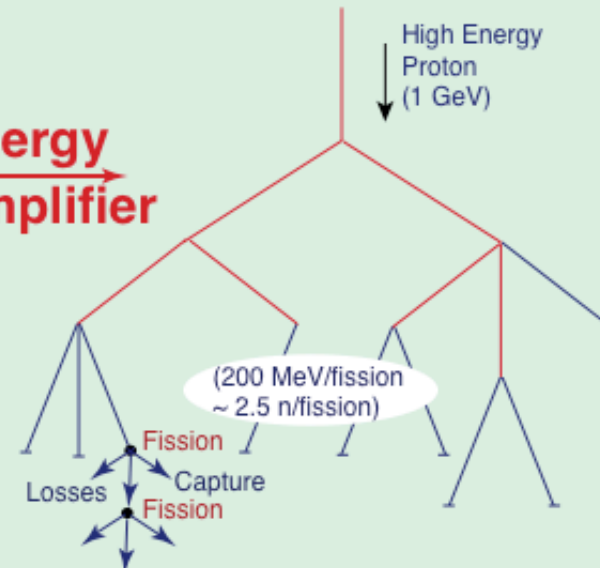

$$\text{Energy gain}(G) = \frac{\text{Energy produced by EA}}{\text{Energy provided by beam}} = \frac{G_0}{1-k}$$

Externally driven process:

$$k < 1 \quad (k = 0.98)$$

$$E_{\text{tot}} = G \times E_p$$

Energy Produced

Beam Energy

⇒ Constant Energy Gain

$$N_0(1 + k + k^2 + k^3 + k^4 + \dots + k^n) = N_0 \frac{k^{n+1} - 1}{k - 1} \approx \frac{N_0}{1 - k}$$

R&D in Europe

Many projects carried out since the EU FP5 and FP6 (Eurotrans) in the field of partitioning and transmutation. All aspects covered.

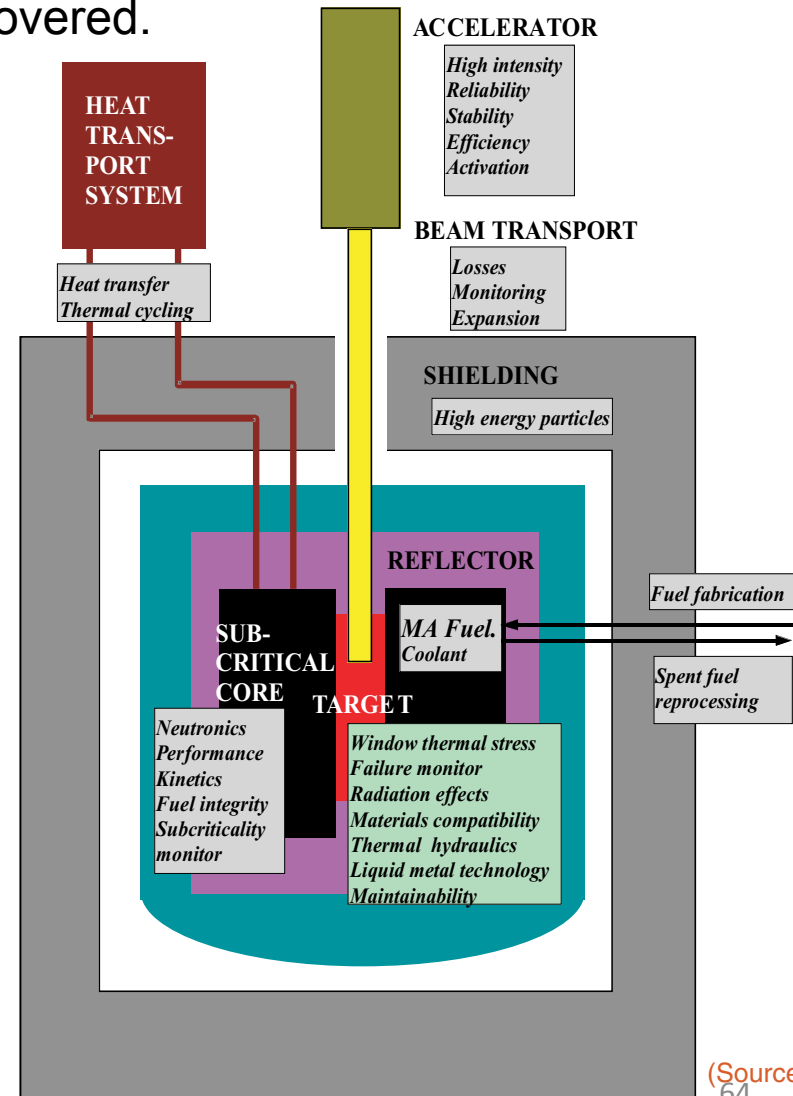
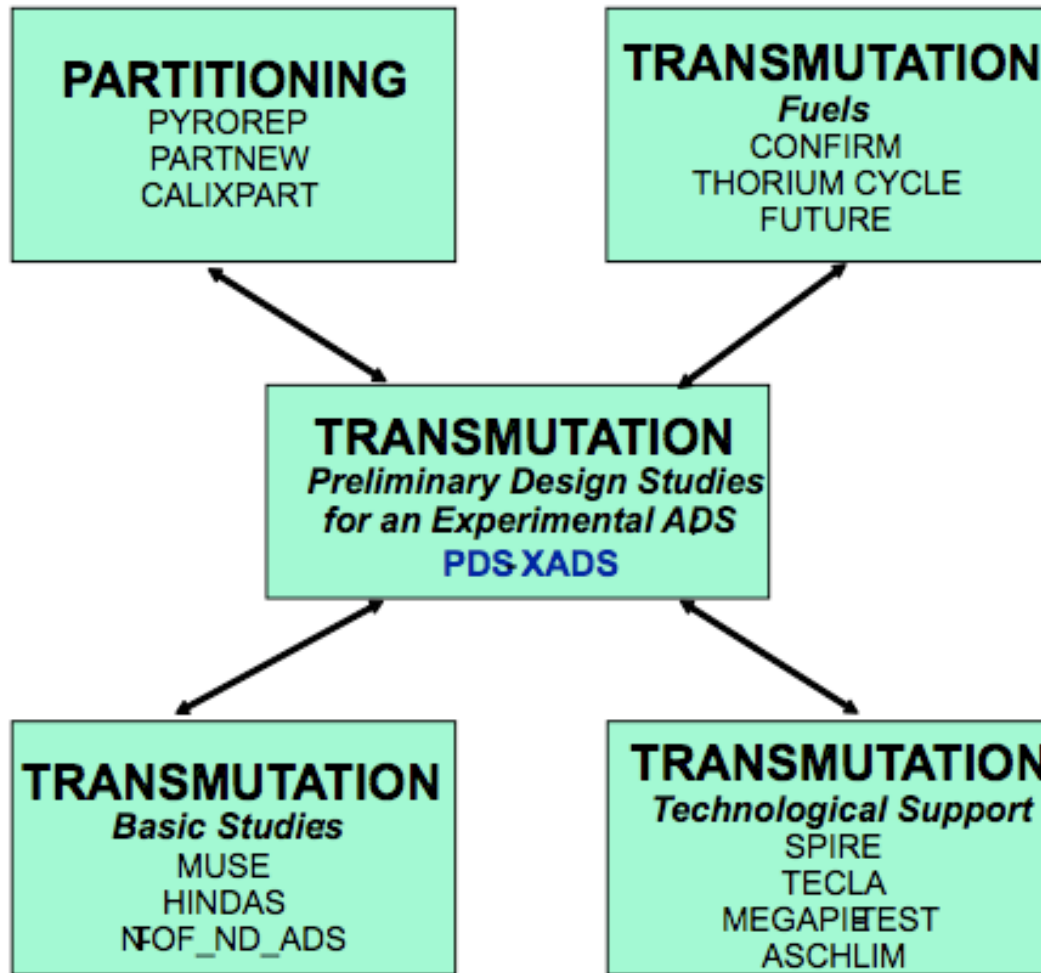

Molten salt ADS

- Several **Molten Salt ADS** concepts were discussed: Carlo Rubbia, Toshinobu Sasa and Laszlo Sajo-Bohus.

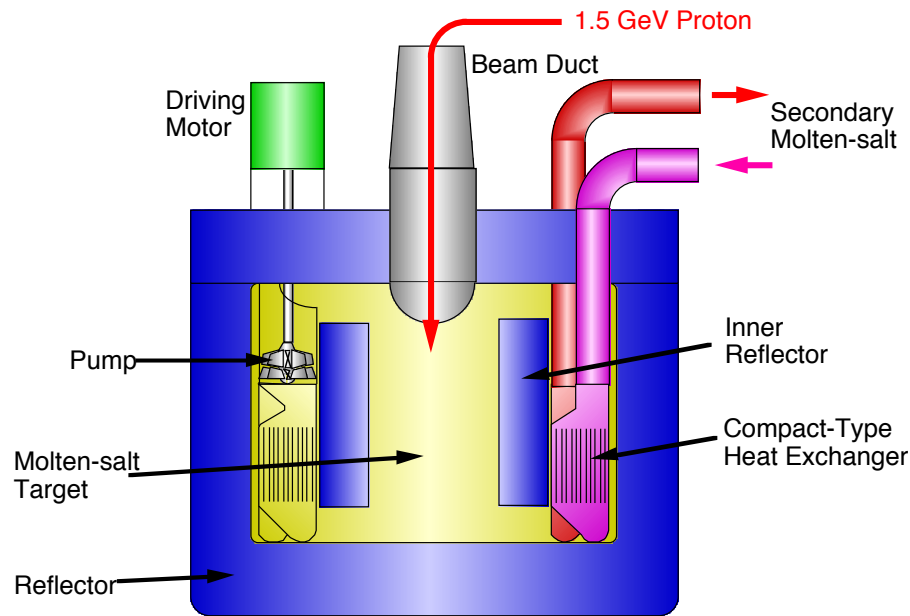

Toshinobu Sasa

MS_ADS
ADMS ?

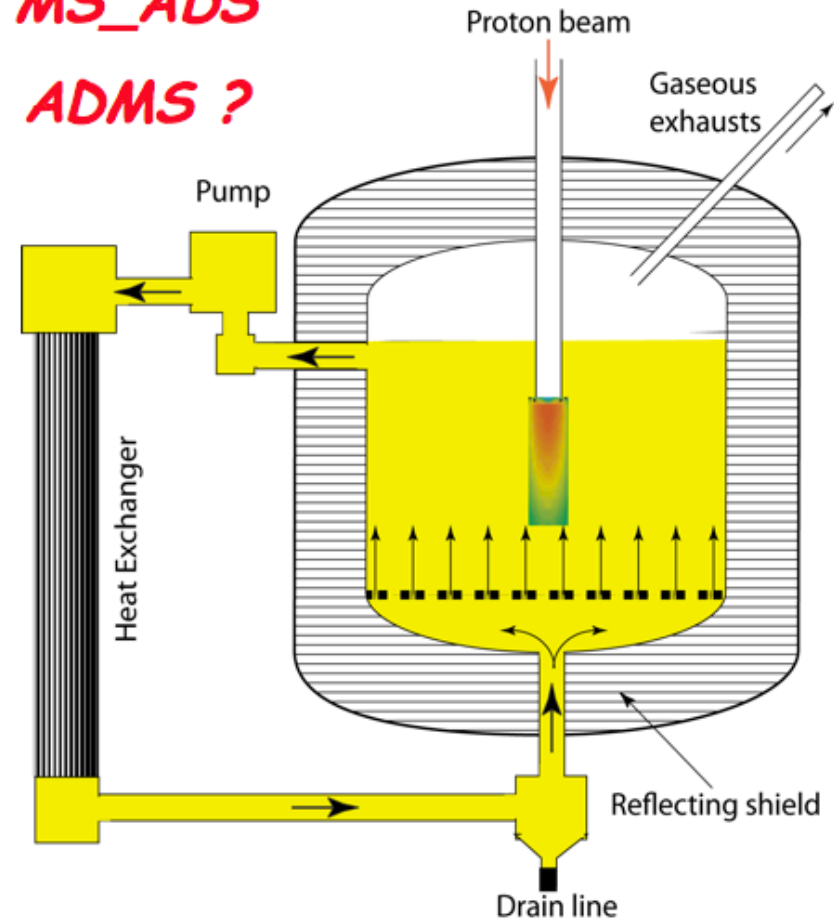

Carlo Rubbia

Detailed simulation

From Pu to asymptotic Th-U mixture

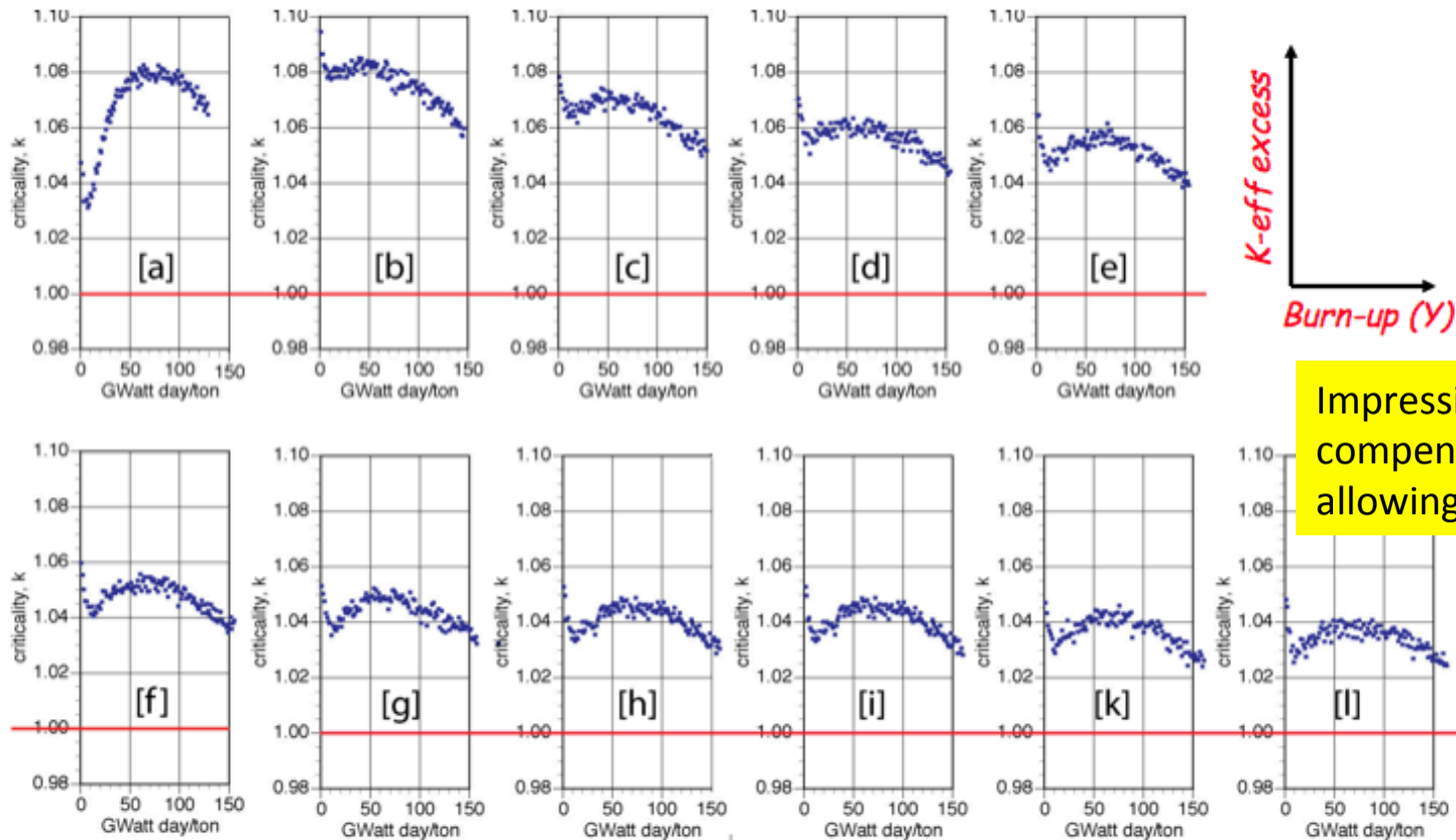

Impressive demonstration of compensation mechanism allowing extended burnup

The appropriate $k < 1$ value is adjusted with the help of control bars

CERN_Oct_2013

Slide# : 31

Carlo Rubbia

Abstract

- **Title:** Thorium: An energy source for the world of tomorrow ?
- **Abstract:** To meet the tremendous world energy needs, systematic R&D has to be pursued to replace fossil fuels. The ThEC13 conference organized by iThEC at CERN last October has shown that thorium is seriously considered by developing countries as a key element of their energy strategy. Developed countries are also starting to move in the same direction. How thorium could make nuclear energy (based on thorium) acceptable to society will be discussed. Thorium can be used both to produce energy and to destroy nuclear waste. As thorium is not fissile, one elegant option is to use an accelerator, in so-called “Accelerator Driven Systems (ADS)”, as suggested by Nobel Prize laureate Carlo Rubbia. CERN’s important contributions to R&D on thorium related issues will be mentioned as well as the main areas where CERN could contribute to this field in the future.

Contents

- The **energy problem**: a global issue
- Review of **R&D on thorium technologies** (ThEC13 thorium conference)
- Possible ways of using **thorium**
- Accelerator Driven Systems (**ADS**)
- CERN contributions to ADS

How much thorium for 1 GWe?

- Calculating the amount of thorium needed for producing 1 GW of thermal energy during one year is a straightforward calculation, based on the fact that the energy released as heat per fission is about **189 MeV** (see later)
- Calculating the amount of thorium needed for producing 1 GW of electrical energy during one year requires one basic assumption:
 - The **electrical conversion efficiency** taken here from the validated simulation of C. Rubbia's Energy Amplifier *C. Rubbia, et al., « Conceptual Design of a Fast Neutron Operated High Power Energy Amplifier »*, CERN/AT/95-44 (ET)

For 1.5 GW of thermal power, 645 GW of electrical power are sent to the Grid (see later)

Energy in fission reactions

- (1) Kinetic energy of fission fragments: 167 MeV
 - (2) Prompt ($< 10^{-6}$ s) gamma ray energy: 8 MeV
 - (3) Kinetic energy of fission neutrons: 8 MeV
 - (4) Gamma ray energy from fission products: 7 MeV
 - (5) Beta decay energy of fission products: 7 MeV
 - (6) Energy as antineutrinos ($\bar{\nu}_e$): 7 MeV
- Adding 1, 2, 4 and 5 (clearly neutrinos do not deposit heat, and fission neutrons are mostly absorbed to induce fissions), one gets:

189 MeV for the contribution to the heat deposition per fission

Energy flow in EA

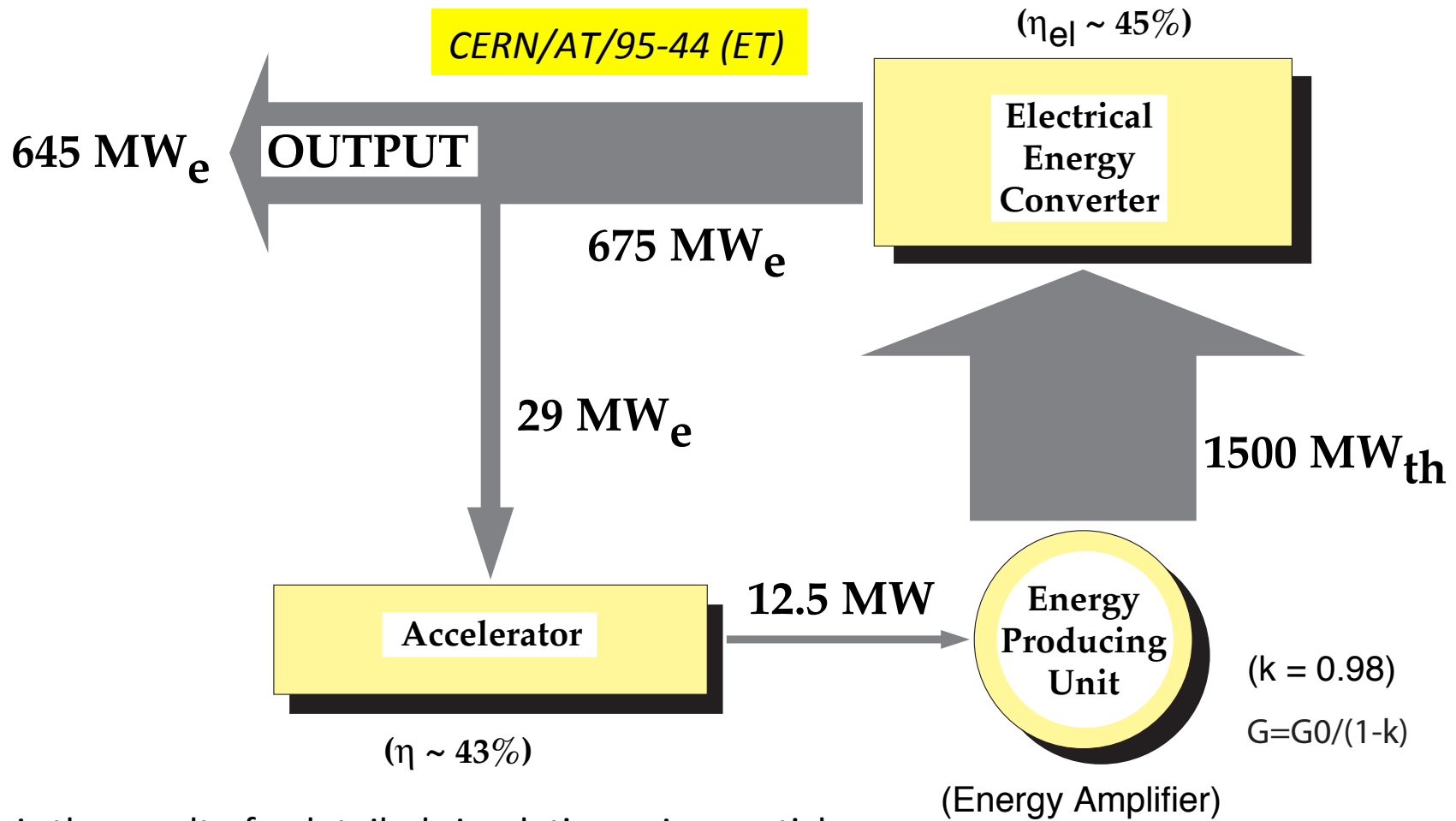

This is the result of a detailed simulation using particle physics methods, starting from single protons in the beam

Amount of thorium

- To produce 645 GWe in a EA requires a thermal power of 1500 MW. Energy during one year:
 $1500 \times 10^6 \times 365 \times 24 \times 3600 = 4.73 \times 10^{16} \text{ Joules}$
- Number of fissions ($1 \text{ eV} = 1.6 \times 10^{-19} \text{ J}$):
 $4.73 \times 10^{16} / (189 \times 10^6 \times 1.6 \times 10^{-19}) = 1.564 \times 10^{27} \text{ fissions}$
- The number of ^{232}Th atoms consumed to have one ^{233}U fission is about **1.127** (see later)
- The mass of ^{232}Th used to produce **1.564×10^{27} fissions** is (molar mass of ^{232}Th is 232.0381 g/mole, and one mole = 6.022×10^{23} atoms):
 $(1.127 \times 1.564 \times 10^{27} / 6.022 \times 10^{23}) \times 232.0381 = 6.79 \times 10^5 \text{ g} = 679 \text{ kg} = 0.679 \text{ t}$

Thorium for 1 GWexYear

- 645 GWe for one year requires **0.679 ton** of thorium in C. Rubbia's Energy Amplifier, hence for **producing 1 GWe during one year takes 1.05 ton of thorium**
- Note that to produce **1 GW of thermal energy during one year requires only 0.453 ton of thorium (6.79 kt of thorium per year for the entire world power consumption of 15 TW)**
- Given that the density of thorium is 11.7 g/cm^3 , it takes a cube of thorium of side **$a = 33.8 \text{ cm}$** to produce 1 GWth during one year!

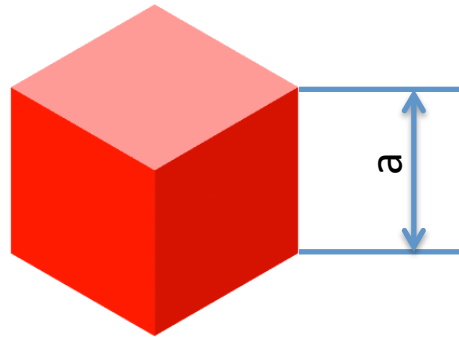

Thorium in the Earth's crust

- According to Wikipedia, the Earth's crust contains 1.2×10^{14} tons of thorium
- Recovering only one part per million (10^{-6}) of this, that is 1.2×10^8 tons, would provide the present world power consumption of 15 TWth, for almost 20'000 years:
 $1.2 \times 10^{14} \times 10^{-6} / 6.79 \times 10^3 = \mathbf{1.77 \times 10^4 \text{ years}}$
 $\approx \mathbf{18'000 \text{ years}}$
- **Thorium is a potentially sustainable source of energy on the human time scale.**

Annual production of a 900MWe PWR

On suppose un rendement de 33% et un facteur de charge de 70%
 (7,9 TWh → 5,5 TWh); typiquement 225kg de TRU et 745 kg de FF.

Electricité	5,5 milliards de kWh
Combustible usagé (à 33,000 MWd/t)	21,5 t de UO₂
Actinides	20 620 kg
Uranium ²³⁸ U (avec 1,1% de ²³⁵ U)	20 400 kg
Plutonium ²³⁹ Pu, ²⁴¹ Pu (71%)	209 kg
Actinides mineurs (Np, Am, Cm, etc.)	16 kg
Fragments de fission (total)	745 kg
Fragments de fissions à vie longue	50 kg
Déchets de classe A (Gaines, matériaux structurels, etc.)	100 – 200 m³

Pyro-electric reprocessing

- ❑ Electrolysis of molten salt solution. Actinides are separated out. Method already tested in the case of Uranium at Argone National Lab (99.99% efficiency achieved). Plutonium remains combined with minor actinides (Np, Am, Cm, etc.). Simpler, nothing goes to the environment (no water) unlike Purex, small dimensions, not proliferating.

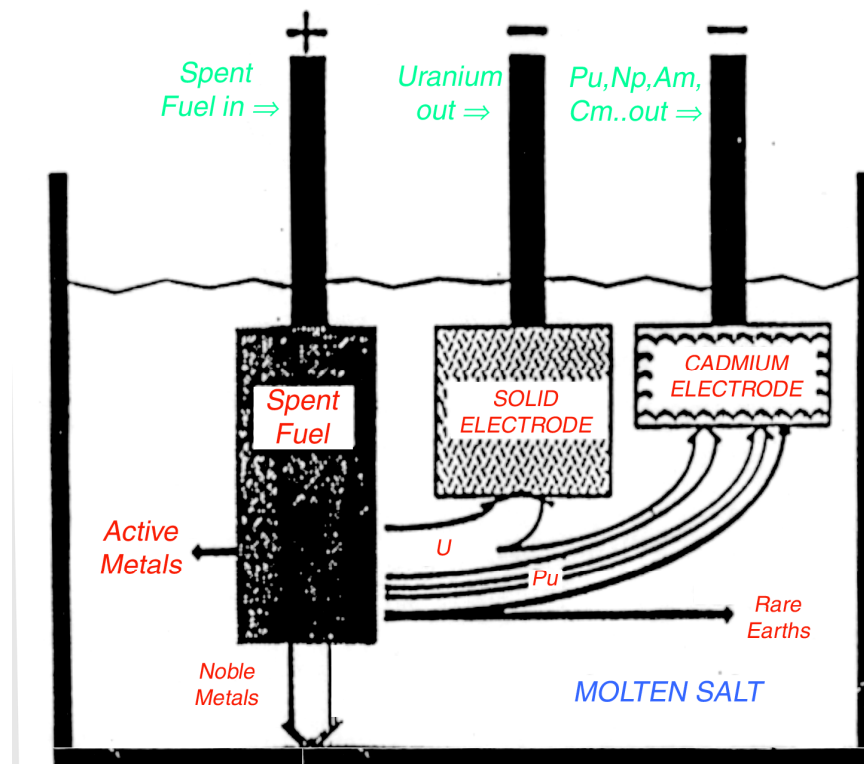

Destruction of nuclear waste

- In a system where elements can be both created and generated, the concentration reaches an equilibrium after a certain time.

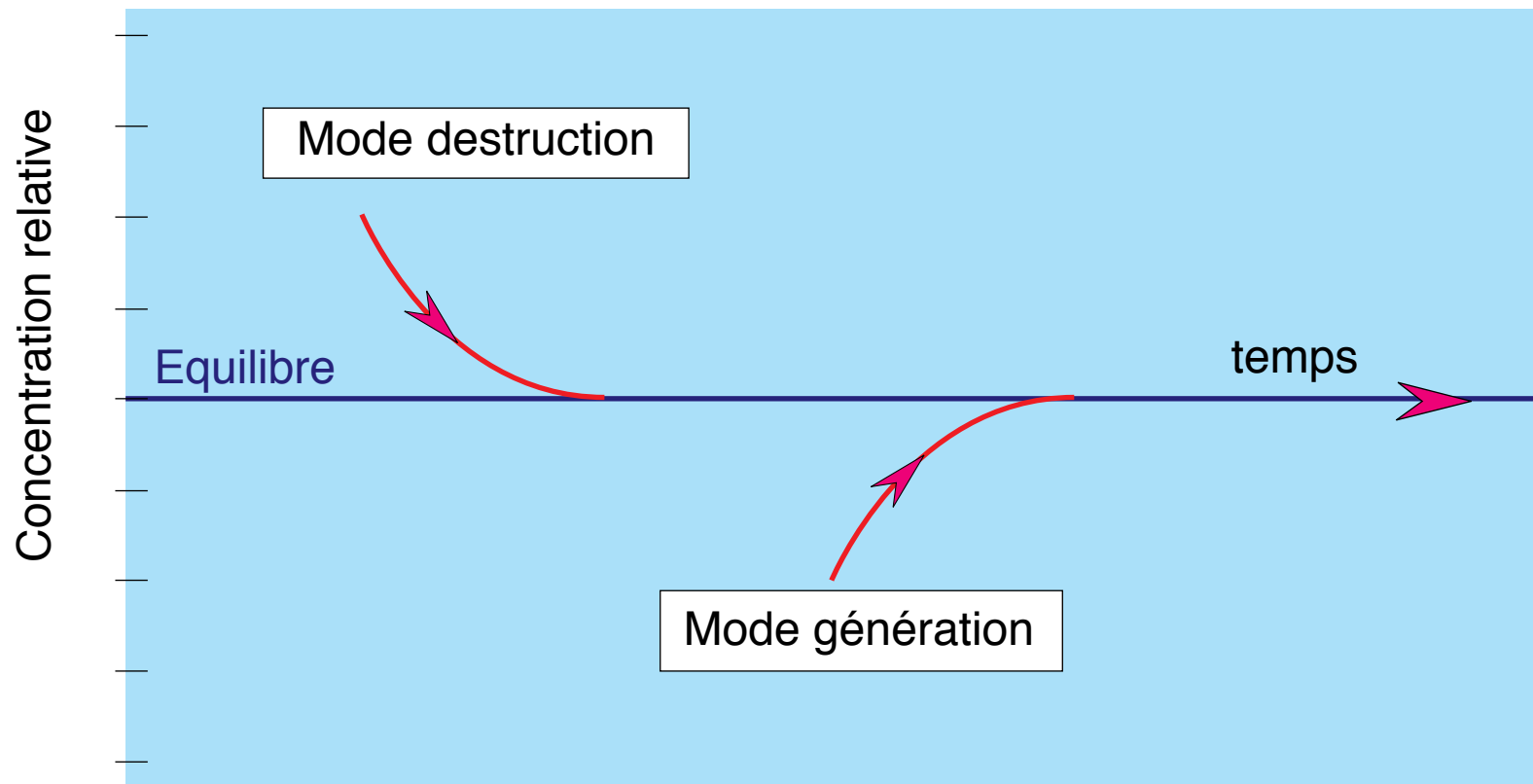

CAPRA (CEA)

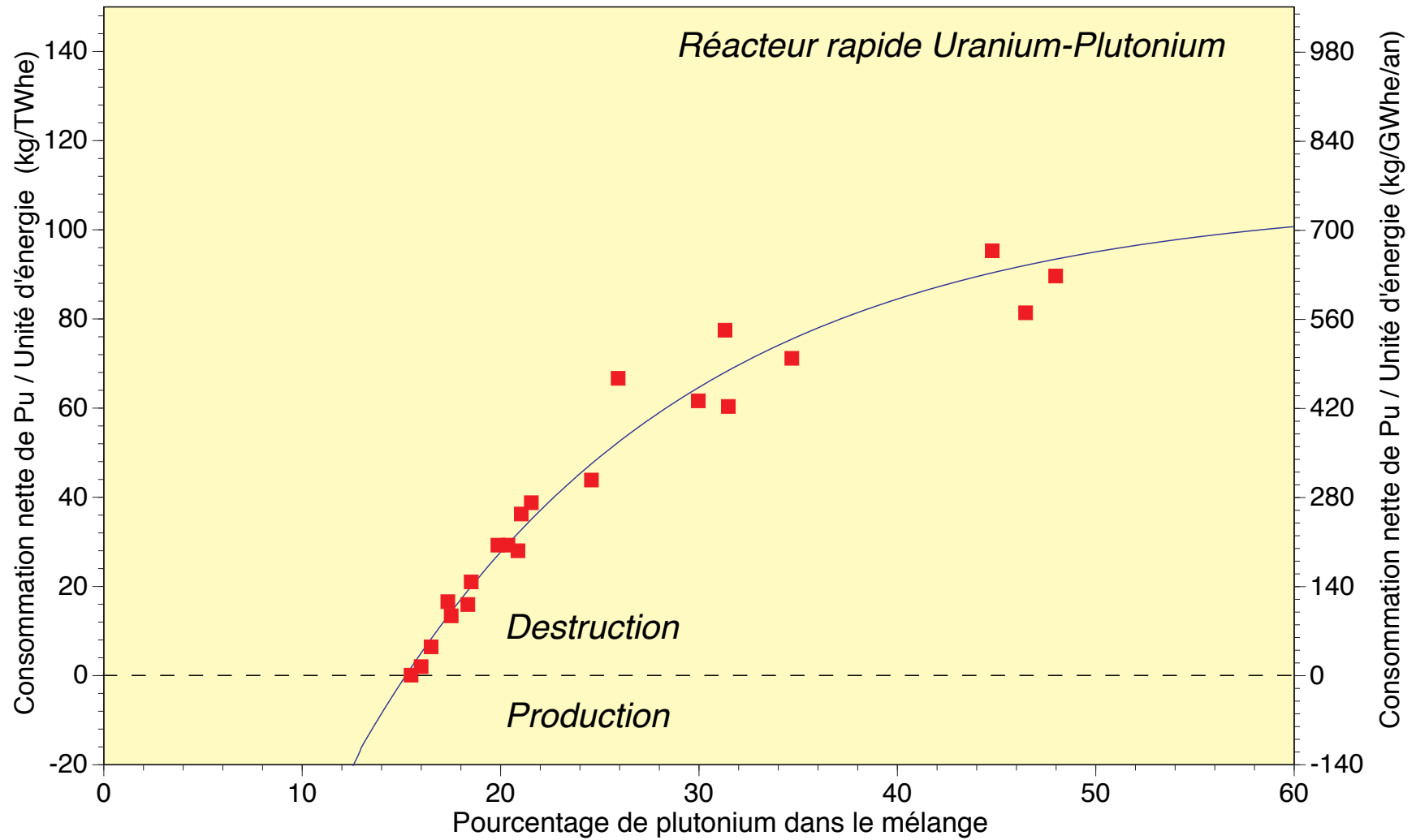

Transmutation of LLFF



ARC maximise le taux de capture de neutrons

